

LittleGIANT®

HVAC PRODUCT CATALOG



BRAND KNOWN

Little Giant the brand has always been the frontrunner in condensate removal pump design. With the widest range of centrifugal tank pumps and over 75 years of history in commercial pumps and pump systems, Little Giant is the most powerful name in air conditioning, heating and refrigeration condensate removal and is recognized worldwide for its quality and reliable products. Little Giant is also known as the brand to use for condensate drain switches and evaporative cooler water pumps. Little Giant HVAC/R products live up to the Franklin Electric's Key Factors for Success - Quality, Availability, Service, Innovation, Cost.

VCMX – NXTGEN MODELS

Save time and money - The VCMX-20 is the easiest condensate pump to install and service plus has the highest reliability in the industry. Product reliability is important because it greatly reduces call backs and continues to save you money after the installation. More contractors choose Little Giant condensate pumps than any other brand for these reasons. From the external test switch to easy-to-mount bracket to the quick, twist-off discharge adapter; VCMX does it all. Contractors not only want a quality product with reliability but also a product they can install with confidence. VCMX-20, available with many optional features, is a versatile, compact pump designed to efficiently pump away condensate for installed in the basement, attached to the side of air conditioning equipment or installed in the ceiling.

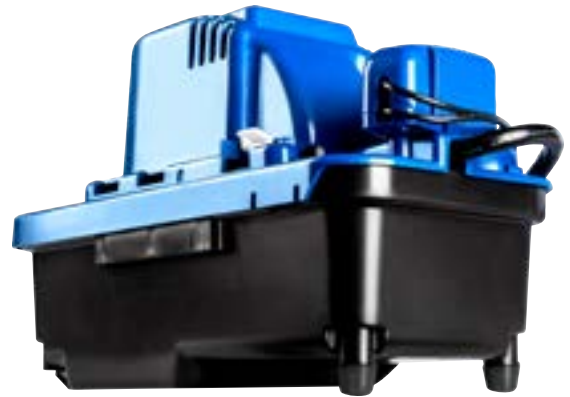

VCC-20-P SERIES FOR PLENUM APPLICATIONS

Conforms to commercial building codes - Whether the condensate producing equipment is installed in a commercial building ceiling or under a raised floor, building codes today require a pump that is designed for Plenum Use. VCC-20-P is the ideal product for this job as it meets UL 2043 Standard: "Fire Test for Heat and Visible Smoke Release of Discrete Products and Their Accessories Installed in Air Handling Space." With its low tank height (designed to fit beneath low hanging condensate producing equipment drain outlet) and special thermoplastic material construction, the conduit ready, hardwired VCC-20-P is the right pump for the job.

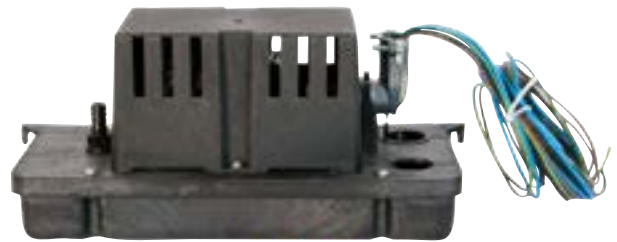

EC-1-DV AND EC-1-DV-K SERIES – MINI-SPLIT

Quiet and easy to install and maintain - Need a mini split condensate that works on any voltage? The Little Giant EC-1-DV Series is the one to choose. The all new EC-1-DV mini pump for ductless mini split or fan-coil equipment meets the demanding requirements for wall mount equipment that may require 115V, 208V or 230V. One model automatically adjusts to the voltage input and delivers smooth, quiet yet powerful pumping performance. With super reliable, automatic water level sensing design with clear collection tank and all the mounting brackets and hardware required, EC-1-DV is the pump to use. EC-1-K-DV includes EC-1-DV pump and line set cover with an easy-to-access pump compartment for "on-the-wall" mounting of the EC-1-DV pump adjacent to the air handler to "hide" the pump and the line set.



TABLE OF CONTENTS

VCMX2
VCMA-15 Series4
VCMA-20 Series6
VCC-20 Series8
VCC-20-P Series10
VCL-14 Series12
VCL-24ULS Series14
VCL-45ULS Series16
1-ABS Series18
2-ABS Series20
3-ABS Series22
EC-1-DV Series24
EC-1K-DV Series26
EC-OP-K Series28
CP Series30
RIM-U Series32
GKPK-SC Series34
ACS-2 & 3 IN-PAN Condensate Overflow Detection Switches36
ACS-4 Series38
ACS-5 Series40
Accessories42
Additional Check Valves43

For the most up-to-date product information, visit littlegiant.com.

VCMX

APPLICATIONS

- Designed for automatic collection and removal of condensate from air conditioning, refrigeration and dehumidification equipment when gravity drainage is not possible or practical. Also suitable for high efficiency oil and gas-fired condensing furnace and condensing boiler equipment.

FEATURES

- External test/run lever
- Slim footprint
- Vertical centrifugal pump design
- Stainless steel motor shaft
- Automatic start and stop operation
- Galvanized steel “quick install” wall mount bracket
- Some models equipped with external, float activated switch for automatic high-level water detection (overflow detection switch)
- For models with overflow detection switch: dual function NO and NC operation (set to NO from factory for equipment shut down connection)
- Models equipped with overflow detection switch include two 5” switch lead wires
- 3/8” O.D. barbed ¼-turn quick release, locking discharge adapter with built-in check valve
- Rubber feet for vibration/noise dampening
- “Anti-sweat” tank sleeve included on select models and available separately for all others
- 3 - 1-1/8” diameter inlet openings, two fitted with removable cap plug (3 + 1 inlet openings for models without overflow detection switch)
- Recessed tank sump
- Oil resistant tank and check valve
- Thermally protected, fan cooled motor
- Maximum water temperature: 140 °F
- 6’, 3-conductor cable with grounded 3-prong plug
- Some models include 20’ x 3/8” I.D. vinyl discharge tubing
- 3-year warranty



VCMX-20ULS



VCMX-20ULST



VCMX-20UL



VCMX-20ULS-C



All Models

SERIES SPECIFICATIONS

NXTGEN™

Item No.	Model	HP	Input Voltage	Hz	Amps	Watts	Discharge Size	Check Valve	Overflow Detection Switch	Performance GPH (LPH) @ Head					Shut-Off Ft.	PSI	Cord	Weight (lbs)
										1'	5'	10'	15'	20'				
554520	VCMX-20UL	1/30	115	60	1.5	93	3/8" (9.5 mm)	3/8" (9.5 mm)	No	84 (318.4)	75 (284.3)	60 (227.4)	42 (159.2)	10 (37.9)	21 (6.4 m)	9.1	6' (1.8 m)	5.5 (2.5 Kg)
554521	VCMX-20UL	1/30	230	50/60	0.7/0.6	75	3/8" (9.5 mm)	3/8" (9.5 mm)	No	78 (295.6)	67 (253.9)	51 (193.3)	29 (109.9)	0 (0)	20 (6.1 m)	8.2	6' (1.8 m)	5.5 (2.5 Kg)
554530	VCMX-20ULS	1/30	115	60	1.5	93	3/8" (9.5 mm)	3/8" (9.5 mm)	Yes	84 (318.4)	75 (284.3)	60 (227.4)	42 (159.2)	10 (37.9)	21 (6.4 m)	9.1	6' (1.8 m)	5.5 (2.5 Kg)
554531	VCMX-20ULS	1/30	230	50/60	0.7/0.6	75	3/8" (9.5 mm)	3/8" (9.5 mm)	Yes	78 (295.6)	67 (253.9)	51 (193.3)	29 (109.9)	0 (0)	20 (6.1 m)	8.2	6' (1.8 m)	5.5 (2.5 Kg)

NXTGEN™ with Tubing

Item No.	Model	HP	Input Voltage	Hz	Amps	Watts	Discharge Size	Check Valve	Overflow Detection Switch	Performance GPH (LPH) @ Head					Shut-Off Ft.	PSI	Cord	Weight (lbs)
										1'	5'	10'	15'	20'				
554550	VCMX-20ULST	1/30	115	60	1.5	93	3/8" (9.5 mm)	3/8" (9.5 mm)	Yes	84 (318.4)	75 (284.3)	60 (227.4)	42 (159.2)	10 (37.9)	21 (6.4 m)	9.1	6' (1.8 m)	5.5 (2.5 Kg)
554551	VCMX-20ULST	1/30	230	50/60	0.7/0.6	75	3/8" (9.5 mm)	3/8" (9.5 mm)	Yes	80 (303.2)	69 (261.5)	54 (204.7)	36 (136.4)	0 (0)	20 (6.1 m)	8.2	6' (1.8 m)	5.5 (2.5 Kg)

NXTGEN™ with Anti-Sweat Sleeve

Item No.	Model	HP	Input Voltage	Hz	Amps	Watts	Discharge Size	Check Valve	Overflow Detection Switch	Performance GPH (LPH) @ Head					Shut-Off Ft.	PSI	Cord	Weight (lbs)
										1'	5'	10'	15'	20'				
554542	VCMX-20ULS-C	1/30	115	60	1.5	93	3/8" (9.5 mm)	3/8" (9.5 mm)	Yes	84 (318.4)	75 (284.3)	60 (227.4)	42 (159.2)	10 (37.9)	21 (6.4 m)	9.1	6' (1.8 m)	5.5 (2.5 Kg)

VCMX

REPLACEMENT PARTS & KITS

Item	Part Number
Tank	154390
Feet, Rubber (4 pack 554520, 554530, 554550, 554551, 554521, 554531)	925047
Cover, Motor	154425
Float Arm Assembly	154460
Check Valve, 3/8"	154724
Overflow Detection Switch Assembly (554530, 554550, 554551, 554542, 554531)	599136
Anti-sweat Sleeve and Bracket (554542)	599138
Bracket, Tank (554520, 554530, 554550, 554551, 554521, 554531)	154483

ENGINEERING DATA

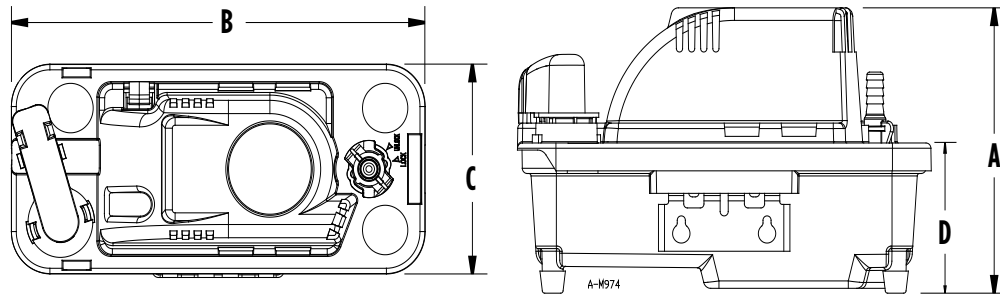

Model	A	B	C	D
VCMX-20UL	6.5" (165.1mm)	10.2" (259.1 mm)	4.8" (121.9 mm)	3.4" (86.4 mm)
VCMX-20ULS	6.5" (165.1mm)	10.2" (259.1 mm)	4.8" (121.9 mm)	3.4" (86.4 mm)
VCMX-20ULST	6.5" (165.1mm)	10.2" (259.1 mm)	4.8" (121.9 mm)	3.4" (86.4 mm)
VCMX-20ULS-C	6.8" (172.7mm)	10.3" (261.6 mm)	5.1" (129.5 mm)	3.4" (86.4 mm)

PERFORMANCE DATA

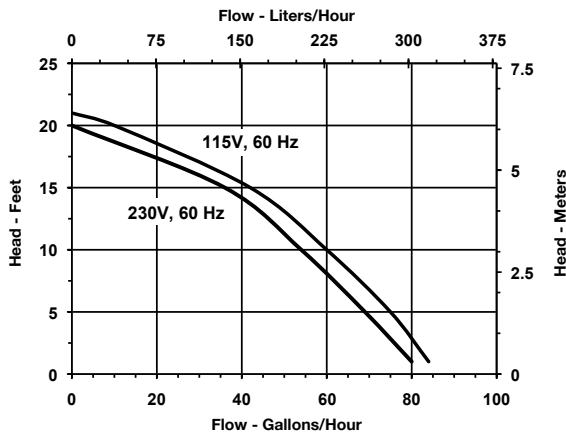

CONSTRUCTION

Housing/Tank Cover	ABS
Motor Cover	ABS
Volute	ABS
Tank	Polypropylene
Impeller	Polypropylene
Switch Float	ABS
Check Valve	Acetal

VCMA-15 SERIES

APPLICATIONS

- Designed for automatic collection and removal of condensate from air conditioning, refrigeration and dehumidification equipment when gravity drainage is not possible or practical. Also, suitable for high efficiency oil and gas-fired condensing furnace and condensing boiler equipment.

FEATURES

- 1/2-gallon collection tank
- Vertical centrifugal pump design
- Stainless steel motor shaft
- Automatic start and stop operation
- Some models equipped with float (solid polymer) activated switch for automatic high-level water detection (overflow detection switch)
- For models with overflow detection switch: dual function NO and NC operation (set to NO from factory for equipment shut down connection)
- Models equipped with overflow detection switch include two 5" switch lead wires
- 3/8" O.D. barbed discharge adapter with built-in check valve
- Three 1-1/8" diameter inlet openings (two fitted with removable cap plug)
- Thermally protected, fan cooled motor
- Built-in wall mount tabs on tank
- Removable pump float locking tab for safety during transportation (remove at time of installation)
- Maximum water temperature: 140 °F
- 6 ft, 3-conductor cable with grounded 3-prong plug
- Some models include 20' x 3/8" I.D. vinyl discharge tubing



SERIES SPECIFICATIONS

Item No.	Model	HP	Input Voltage	Hz	Amps	Watts	Discharge Size	Performance GPH (LPH) @ Head				Shut-Off Ft.	PSI	Cord	Weight (lbs)
								1'	5'	10'	20'				
554401	VCMA-15UL	1/50	115	60	1	60	3/8" (9.5 mm) OD Barbed	65 (246.4)	50 (189.5)	25 (94.8)	0 (0)	15 (4.6 m)	6.5	6 (1.8 m)	4.4 (2 kg)
554411	VCMA-15ULT	1/50	115	60	1	60	3/8" (9.5 mm) OD Barbed	65 (246.4)	50 (189.5)	25 (94.8)	0 (0)	15 (4.6 m)	6.5	6 (1.8 m)	5.8 (2.6 Kg)
554405	VCMA-15ULS	1/50	115	60	1	60	3/8" (9.5 mm) OD Barbed	65 (246.4)	50 (189.5)	25 (94.8)	0 (0)	15 (4.6 m)	6.5	6 (1.8 m)	4.4 (2 kg)
554415	VCMA-15ULST	1/50	115	60	1	60	3/8" (9.5 mm) OD Barbed	65 (246.4)	50 (189.5)	25 (94.8)	0 (0)	15 (4.6 m)	6.5	6 (1.8 m)	5.8 (2.6 Kg)

Note: GPH is through check valve.

VCMA-15 SERIES

REPLACEMENT PARTS & KITS

Item	Part Number
Tank	154401
Cover, Motor	154421
Float Arm	154452
Switch Holder	154471
Switch	950337
Check Valve	154715

ENGINEERING DATA

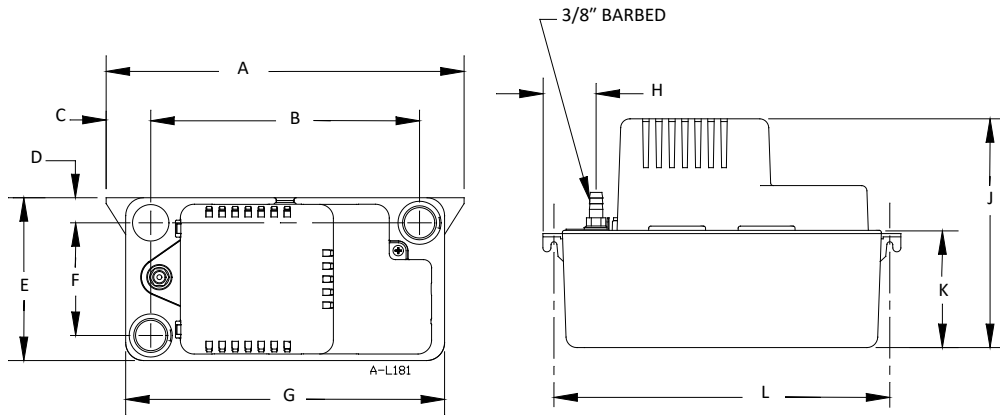

A	B	C	D	E	F	G	H	J	K	L
11 (279.4)	8.3 (210.82)	1.4 (35.56)	0.8 (20.32)	5 (127)	3.5 (88.9)	9.8 (248.92)	1.6 (400.64)	7 (177.8)	3.6 (91.4)	10.3 (261.6)

PERFORMANCE DATA

115 V, 60 HZ

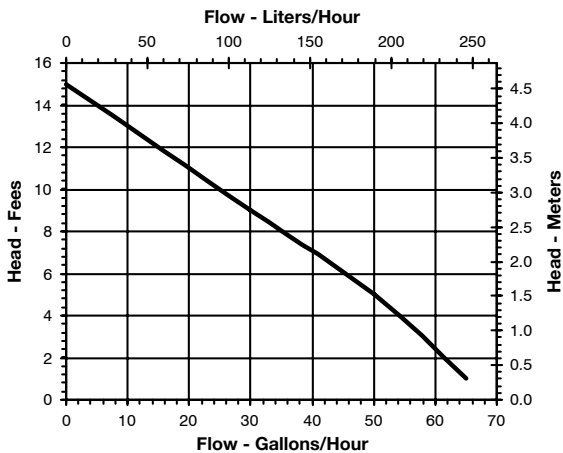

CONSTRUCTION

Motor	1/50 hp
Discharge	3/8" OD barbed
Housing/Tank Cover	ABS
Motor Cover	ABS
Volute	ABS
Tank	ABS
Impeller	Glass filled polypropylene
Check Valve	Acetal

VCMA-20 SERIES

APPLICATIONS

- Designed for automatic collection and removal of condensate from air conditioning, refrigeration and dehumidification equipment when gravity drainage is not possible or practical. Also, suitable for high efficiency oil and gas-fired condensing furnace and condensing boiler equipment.

FEATURES

- 1/2-gallon collection tank
- Vertical centrifugal pump design
- Stainless steel motor shaft
- Automatic start and stop operation
- Some models equipped with float (solid polymer) activated switch for automatic high-level water detection (overflow detection switch)
- For models with overflow detection switch: dual function NO and NC operation (set to NO from factory for equipment shut down connection)
- Models equipped with overflow detection switch include two 5" switch lead wires
- 3/8" O.D. barbed discharge adapter with built-in check valve
- Three 1-1/8" diameter inlet openings (two fitted with removable cap plug)
- Thermally protected, fan cooled motor
- Built-in wall mount tabs on tank
- Removable pump float locking tab for safety during transportation (remove at time of installation)
- Maximum water temperature: 140 °F
- 6 ft, 3-conductor cable with grounded 3-prong plug
- Some models include 20' x 3/8" I.D. vinyl discharge tubing



SERIES SPECIFICATIONS

Item No.	Model	HP	Input Voltage	Hz	Amps	Watts	Discharge Size	Performance GPH (LPH) @ Head				Shut-Off Ft.	PSI	Cord	Weight (lbs)
								1'	5'	10'	20'				
554421	VCMA-20UL	1/30	115	60	1.5	93	3/8" (9.5mm) OD Barbed	80 (303.2)	70 (265.3)	48 (181.9)	0 (0)	20 (6.1 m)	8.7	6 (1.8 m)	5 (2.3 Kg)
554451	VCMA-20UL	1/30	230	50/60	0.5	75	3/8" (9.5mm) OD Barbed	80 (303.2)	70 (265.3)	48 (181.9)	0 (0)	17 (5.2 m)	7.4	6 (1.8 m)	5 (2.3 Kg)
554431	VCMA-20ULT	1/30	115	60	1.5	93	3/8" (9.5mm) OD Barbed	80 (303.2)	70 (265.3)	48 (181.9)	0 (0)	20 (6.1 m)	8.7	6 (1.8 m)	6 (2.7 Kg)
554425	VCMA-20ULS	1/30	115	60	1.5	93	3/8" (9.5mm) OD Barbed	80 (303.2)	70 (265.3)	48 (181.9)	0 (0)	20 (6.1 m)	8.7	6 (1.8 m)	5 (2.3 Kg)
554455	VCMA-20ULS	1/30	230	50/60	0.5	75	3/8" (9.5mm) OD Barbed	80 (303.2)	70 (265.3)	48 (181.9)	0 (0)	17 (5.2 m)	7.4	6 (1.8 m)	5 (2.3 Kg)
554435	VCMA-20ULST	1/30	115	60	1.5	93	3/8" (9.5mm) OD Barbed	80 (303.2)	70 (265.3)	48 (181.9)	0 (0)	20 (6.1 m)	8.7	6 (1.8 m)	6.3 (2.9 Kg)
554461	VCMA-20ULST	1/30	230	60	0.5	75	3/8" (9.5mm) OD Barbed	80 (303.2)	70 (265.3)	48 (181.9)	0 (0)	17 (5.2 m)	7.4	6 (1.8 m)	6.3 (2.9 Kg)

Note: GPH is through check valve.

VCMA-20 SERIES

REPLACEMENT PARTS & KITS

Item	Part Number
Tank	154401
Cover, Motor	154421
Float Arm	154452
Switch Holder	154471
Switch	950337

ENGINEERING DATA

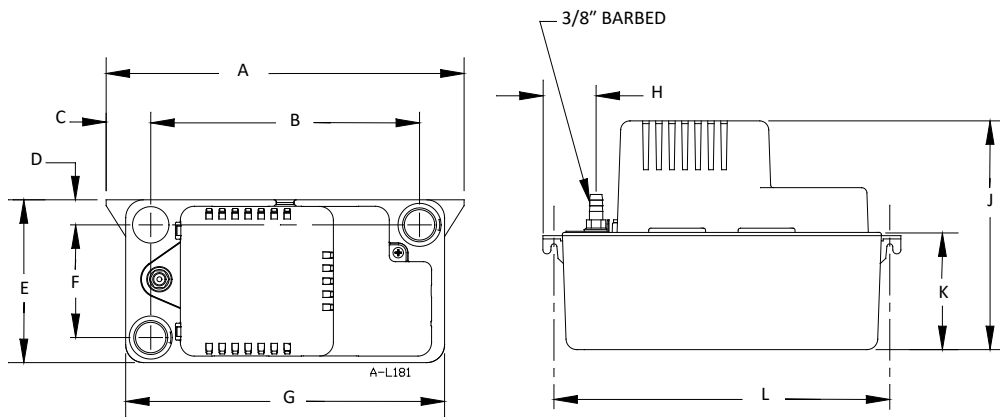

A	B	C	D	E	F	G	H	J	K	L
11 (279.4)	8.3 (210.82)	1.4 (35.56)	0.8 (20.32)	5 (127)	3.5 (88.9)	9.8 (248.92)	1.6 (400.64)	7 (177.8)	3.6 (91.4)	10.3 (261.6)

PERFORMANCE DATA

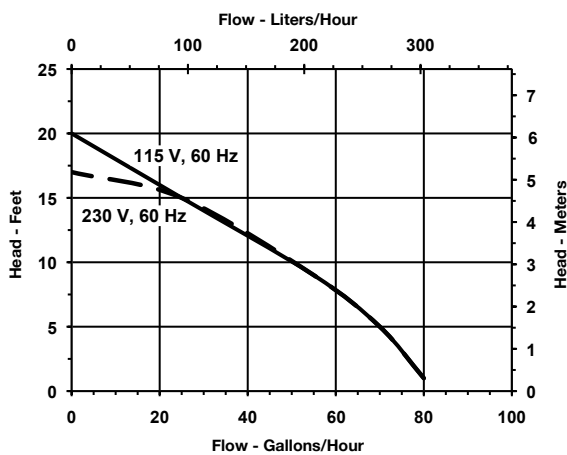

CONSTRUCTION

Motor	1/30 hp
Discharge	3/8" OD barbed
Housing/Tank Cover	ABS
Volute	ABS
Tank	ABS
Impeller	Glass filled polypropylene
Check Valve	Acetal

VCC-20 SERIES

APPLICATIONS

- Designed for automatic collection and removal of condensate from air conditioning, refrigeration and dehumidification equipment when gravity drainage is not possible or practical. Also, suitable for high efficiency oil and gas-fired condensing furnace and condensing boiler equipment.

FEATURES

- Low profile for limited spaces
- Vertical centrifugal pump design
- Stainless steel motor shaft
- Automatic start, stop and high-level water detection (overflow detection switch)
- 3/8" O.D. barbed discharge adapter with built-in check valve (installed on the pump)
- 1/4" O.D. barbed discharge adapter (included in the box)
- Two inlet openings 1-1/8"
- Overflow detection float activated switch
- Two 5" overflow detection switch lead wires
- Thermally protected, fan cooled motor
- Intermittent liquid temperature up to 120 °F
- 6 ft, 3-conductor cable with grounded 3-prong plug (115 V and 230 V models)



SERIES SPECIFICATIONS

Item No.	Model	HP	Input Voltage	Hz	Amps	Watts	Discharge Size	Performance GPH (LPH) @ Head				Shut-Off Ft.	PSI	Cord	Weight (lbs)
								1'	5'	10'	20'				
554200	VCC-20ULS	1/30	115	60	1.5	93	3/8" (9.5 mm) OD Barbed	80 (303.2)	70 (265.3)	45 (170.6)	0 (0)	20 (6.1 m)	8.6	6 (1.8 m)	5.4 (2.5 Kg)
554210	VCC-20ULS	1/30	230	50/60	0.6/0.5	75	3/8" (9.5 mm) OD Barbed	80 (303.2)	70 (265.3)	45 (170.6)	0 (0)	17 (5.2 m)	7.4	6 (1.8 m)	5.4 (2.5 Kg)

Note: GPH is through check valve.

VCC-20 SERIES

REPLACEMENT PARTS & KITS

Item	Part Number
Tank	154004
Impeller	154009
Volute	154015
Cover, Motor	154006
Check Valve	154715
Switch Pump	950337
Seal Ring	928006
Overflow Detection Switch	154714
Float/Stem	154017
Adapter, 1/4"	154037

ENGINEERING DATA

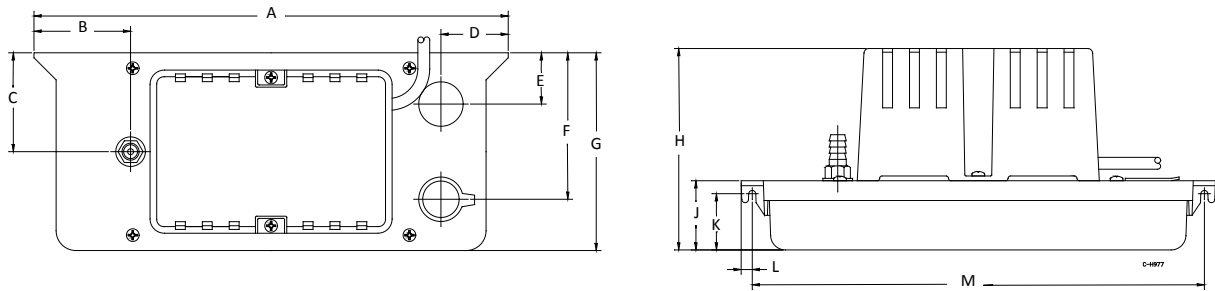

A	B	C	D	E	F	G	H	J	K	L	M
12 (304.8)	2.44 (62)	2.5 (63.5)	1.7 (43.2)	1.3 (33)	3.7 (94)	5 (127)	5.09 (129.3)	1.75 (44.5)	1.42 (36.1)	0.28 (7.1)	11.44 (290.6)

PERFORMANCE DATA

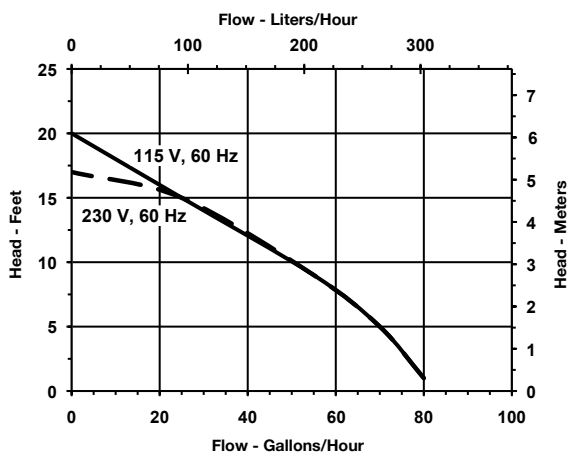

CONSTRUCTION

Motor	1/30 hp
Discharge	3/8" OD barbed
Housing/Tank Cover	ABS
Motor Cover	ABS
Volute	ABS
Tank	ABS
Impeller	Glass filled polypropylene
Check Valve	Acetal

VCC-20-P SERIES

APPLICATIONS

- Designed for automatic collection and removal of condensate from air conditioning, refrigeration, and dehumidification equipment installed in air handling and plenum applications having limited space and where gravity drainage is not possible or practical.
- The VCC-20-P is constructed with plastics that have been tested by Underwriter's Laboratories' to UL Standard 2043 "Fire Test for Heat and Visible Smoke Release for Discrete Products and Their Accessories Installed in Air Handling Spaces".



For Plenum Applications



FEATURES

- The pump meets the requirements of UL 2043 and is labeled "For Plenum Applications"
- 1/30 hp motor
- 1-3/4" low profile tank height ideal for tight spaces
- Vertical centrifugal pump design
- 1.2-quart (1.1 liters) capacity tank
- Automatic start and stop switch
- 3/8" O.D. barbed discharge adapter with built-in check valve (installed on the pump)
- 1-1/8" diameter inlet
- Float-activated auxiliary high-level switch
 - Two 72" high-level switch lead wires
- Thermally protected, fan-cooled motor
- Intermittent liquid temperature up to 140 °F
- Designed for hard-wire installation only
- 72" 3-conductor lead wires with conduit fitting for 1/2" diameter flexible metal conduit
- Stainless motor shaft

SERIES SPECIFICATIONS

Item No.	Model	HP	Input Voltage	Hz	Amps	Watts	Discharge Size	Performance GPH (LPH) @ Head				Shut-Off Ft.	PSI	Cord	Weight (lbs)
								1'	5'	10'	20'				
554220101	VCC-20-P	1/30	115	60	1.5	93	3/8" (9.5 mm) OD Barbed	80 (303.2)	70 (265.3)	45 (170.6)	0 (0)	20'	8.6	72" (183 cm)	4.5 lbs/2.05 kg
554220102	VCC-20-P	1/30	230	50/60	0.6/0.5	60	3/8" (9.5 mm) OD Barbed	80 (303.2)	70 (265.3)	45 (170.6)	0 (0)	17'	7.4	72" (183 cm)	4.5 lbs/2.05 kg

Note: GPH is through check valve.

VCC-20-P SERIES

ENGINEERING DATA

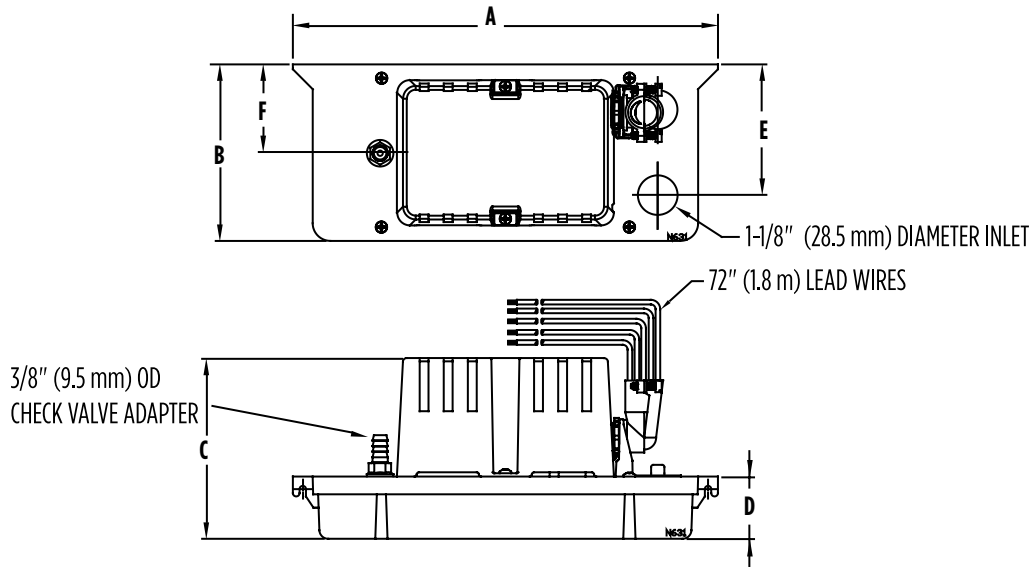

A	B	C	D	E	F
12" (304.8 mm)	5" (127 mm)	5.09" (129.31 mm)	1.75" (44.6 mm)	3.70" (93.9 mm)	2.50" (63.5mm)

PERFORMANCE DATA

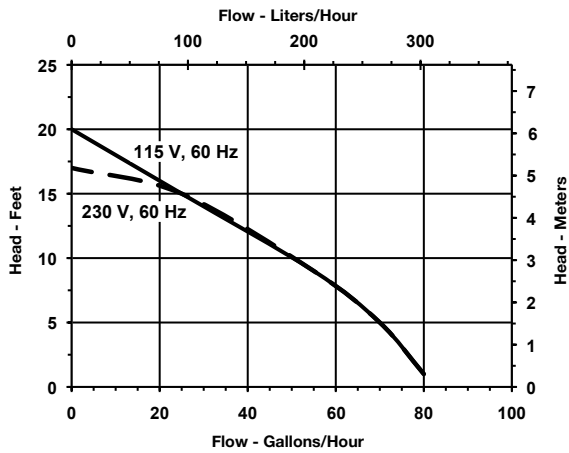

CONSTRUCTION

Tank	G.F. Polypropylene
Tank Cover	G.F. Polypropylene
Motor/Switch Cover	G.F. Polypropylene
Volute Cover	G.F. Polypropylene
Impeller	G.F. Polypropylene
Volute Cover Seal Ring	EPDM
Check Valve /Adapter	Acetal
Motor Shaft	Stainless Steel
Fasteners	Stainless Steel

VCL-14 SERIES

APPLICATIONS

- Designed for automatic collection and removal of condensate from air conditioning, refrigeration and dehumidification equipment when gravity drainage is not possible or practical. Also, suitable for high efficiency oil and gas-fired condensing furnace and condensing boiler equipment.

FEATURES

- 1 gallon collection tank
- 1/50 hp, fan cooled, concentric motor
- Vertical centrifugal pump design
- Stainless steel motor shaft
- Automatic start and stop operation
- Includes float (solid polymer) activated switch for automatic high-level water detection (overflow detection switch)
- Overflow detection switch: dual function NO and NC operation (set to NO from factory for equipment shut down connection)
- Overflow detection switch includes two 5" switch lead wires
- 3/8" barbed discharge adapter (for use with 3/8" I.D. vinyl tubing)*
- *Optional check valve adapter for 3/8" vinyl tubing sold separately (Part Number 599065)
- *Optional check valve for 3/8" copper tube sold separately (Part Number 599063)
- Two 1-1/8" diameter inlet openings
- Thermally protected
- Maximum water temperature: 120 °F
- 6 ft, 3-conductor cable with grounded 3-prong plug



SERIES SPECIFICATIONS

Item No.	Model	HP	Input Voltage	Hz	Amps	Watts	Discharge Size	Performance GPH (LPH) @ Head				Shut-Off Ft.	PSI	Cord	Weight (lbs)
								1'	3'	5'	10'				
553101	VCL-14ULS	1/50	115	60	1.0	78	3/8" (9.5 mm) OD Barbed	200 (758)	185 (701)	170 (644.3)	125 (473.8)	14 (4.3 m)	6.1	6 (1.8 m)	6.8 (3.08 Kg)

VCL-14 SERIES

REPLACEMENT PARTS & KITS

Item	Part Number
Tank	153502
Cover, Volute	153110
Impeller	153132
Adapter, 3/8"	153300
Seal Ring	924038
Switch, Pump	950337
Overflow Detection Switch	950333

ENGINEERING DATA

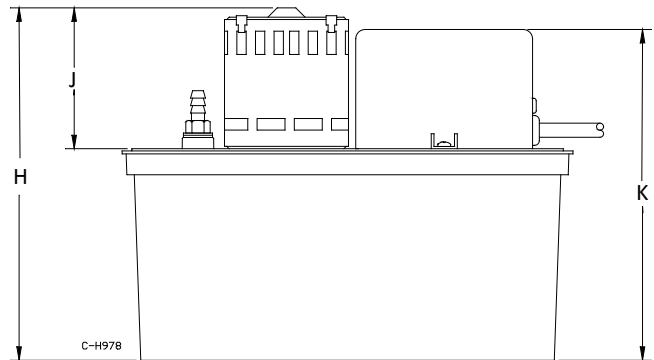
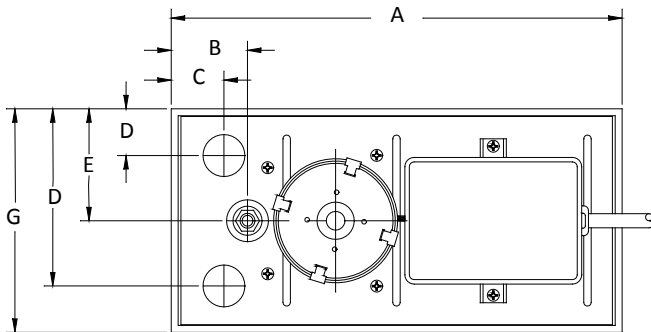

A	B	C	D	E	F	G	H	J	K
12.1 (307.34)	2.04 (51.82)	1.4 (35.56)	1.25 (31.75)	3 (76.2)	4.75 (120.65)	6 (152.4)	9.46 (240.28)	3.78 (96.01)	8.88 (225.55)

PERFORMANCE DATA

115 V, 60 HZ

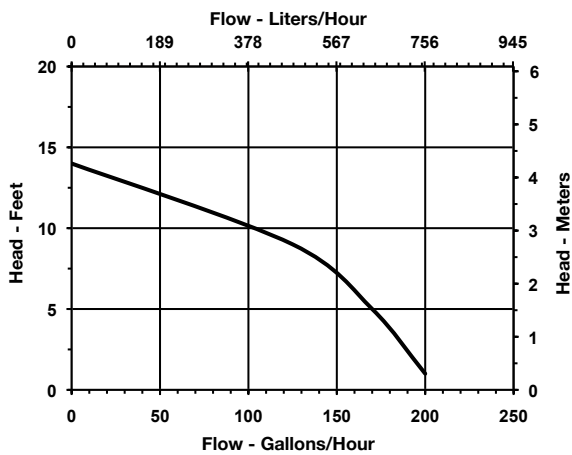

CONSTRUCTION

Motor	1/50 hp
Discharge	3/8" OD barbed
Pump Housing	ABS
Switch Housing	ABS
Tank	ABS
Tank Cover	Galvanized Steel
Motor Shaft	Stainless Steel
Impeller	Polypropylene
Discharge Adapter	Acetal

VCL-24ULS SERIES

APPLICATIONS

- Designed for automatic collection and removal of condensate from air conditioning, refrigeration and dehumidification equipment when gravity drainage is not possible or practical. Also, suitable for high efficiency oil and gas-fired condensing furnace and condensing boiler equipment.

FEATURES

- 1 gallon collection tank
- Vertical centrifugal pump design
- 1/18 hp, fan cooled, concentric motor
- Stainless steel motor shaft
- Automatic start and stop operation
- Includes float (solid polymer) activated switch for automatic high-level water detection (overflow detection switch)
- Overflow detection switch: dual function NO and NC operation (set to NO from factory for equipment shut down connection)
- Overflow detection switch includes two 5" switch lead wires
- 3/8" barbed discharge adapter (for use with 3/8" I.D. vinyl tubing)* installed
- *Optional check valve adapter for 3/8" vinyl tubing included in box
- *Optional check valve for 3/8" O.D. copper tube sold separately (Part Number 599063)
- Two 1-1/8" diameter inlet openings
- Thermally protected, fan cooled motor
- Maximum water temperature: 120 °F
- 6 ft, 3-conductor cable with grounded 3-prong plug



SERIES SPECIFICATIONS

Item No.	Model	HP	Input Voltage	Hz	Amps	Watts	Discharge Size	Performance GPH (LPH) @ Head				Shut-Off Ft.	PSI	Cord	Weight (lbs)
								1'	3'	5'	9'				
553206	VCL-24UL	1/18	115	60	2.5	148	1/4" FNPT x 3/8" (9.5 mm) OD Barbed	270 (1023.3)	260 (985.4)	250 (947.5)	210 (796)	24 (7.3 m)	10.4	6 (1.8 m)	8.2 (3.7 Kg)
553201	VCL-24ULS	1/18	115	60	2.5	148	1/4" FNPT x 3/8" (9.5 mm) OD Barbed	270 (1023.3)	260 (985.4)	250 (947.5)	210 (796)	24 (7.3 m)	10.4	6 (1.8 m)	8.2 (3.7 Kg)
14940371	VCL-24ULS*	1/18	115	60	2.5	148	1/4" FNPT x 3/8" (9.5 mm) OD Barbed	270 (1023.3)	260 (985.4)	250 (947.5)	210 (796)	24 (7.3 m)	10.4	6 (1.8 m)	9.25
553211	VCL-24ULS	1/18	230	50/60	1.2	148	1/4" FNPT x 3/8" (9.5 mm) OD Barbed	270 (1023.3)	260 (985.4)	250 (947.5)	210 (796)	24 (7.3 m)	10.4	6 (1.8 m)	8.2 (3.7 Kg)
14940372	VCL-24ULS*	1/18	230	50/60	1.2	148	1/4" FNPT x 3/8" (9.5 mm) OD Barbed	270 (1023.3)	260 (985.4)	250 (947.5)	210 (796)	24 (7.3 m)	10.4	6 (1.8 m)	9.25 (14.2 Kg)

Note: 3/8" ID x 20 ft. tubing

VCL-24ULS SERIES

REPLACEMENT PARTS & KITS

Item	Part Number
Tank	153502
Cover, Volute	153110
Impeller	153131
Adapter, 3/8"	153300
Seal Ring	924038
Switch, Pump	950337
Overflow Detection Switch	950333

ENGINEERING DATA

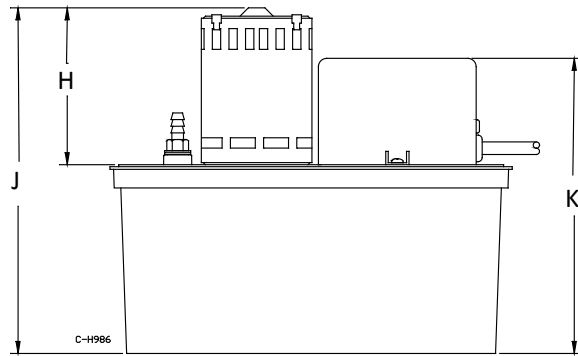
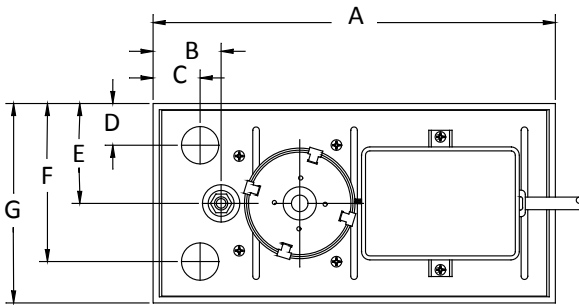

A	B	C	D	E	F	G	H	J	K
12.11 (307.59)	2.04 (51.82)	1 (25.4)	1.25 (31.75)	3 (76.2)	4.75 (120.65)	6 (152.4)	4.72 (119.89)	10.4 (264.16)	8.88 (225.55)

PERFORMANCE DATA

115 V AND 230 V, 60 HZ

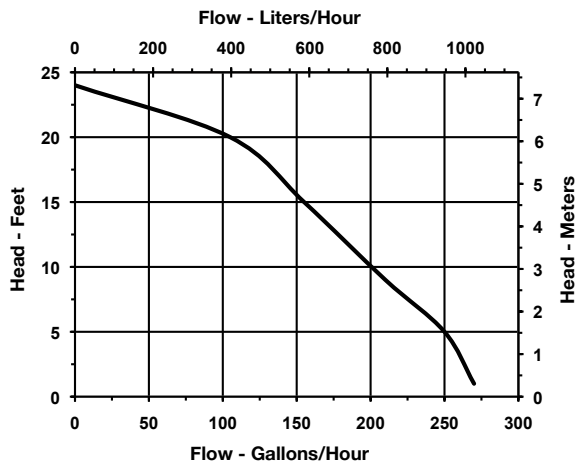

CONSTRUCTION

Pump Housing	ABS
Switch Housing	ABS
Tank	ABS
Tank Cover	Galvanized Steel
Motor Shaft	Stainless Steel
Impeller	Polypropylene
Discharge Adapter	Acetal

VCL-45ULS SERIES

APPLICATIONS

- Designed for automatic collection and removal of condensate from air conditioning, refrigeration and dehumidification equipment when gravity drainage is not possible or practical. Also, suitable for high efficiency oil and gas-fired condensing furnace and condensing boiler equipment.

FEATURES

- 1 gallon collection tank
- Vertical centrifugal pump design
- 1/5 hp, fan cooled, PSC motor
- Stainless steel motor shaft
- Automatic start and stop operation
- Includes float (solid polymer) activated switch for automatic high-level water detection (overflow detection switch)
- Overflow detection switch: dual function NO and NC operation (set to NO from factory for equipment shut down connection)
- Overflow detection switch includes two 5" switch lead wires
- 3/8" O.D. copper tubing discharge
- *Optional check valve adapter for 3/8" O.D. copper tubing/3/8" I.D. vinyl tubing sold separately (Part Number 599064)
- 1-1/8" diameter inlet opening
- Thermally protected motor
- Maximum water temperature: 120 °F
- 6 ft, 3-conductor cable with grounded 3-prong plug



SERIES SPECIFICATIONS

Item No.	Model	HP	Input Voltage	Hz	Amps	Watts	Discharge Size	Performance GPH (LPH) @ Head					Shut-Off Ft.	PSI	Cord	Weight (lbs)
								1'	3'	5'	9'	15'				
553240	VCL-45ULS	1/5	115	60	3.5	185	3/8" (9.5 mm) OD Copper	450 (1705.5)	445 (1686.6)	440 (1667.6)	415 (1572.9)	380 (1440.2)	45 (13.7 m)	19.5	6 (1.8 m)	13 (5.9 Kg)
553245	VCL-45ULS	1/5	230	50/60	1.0	250	3/8" (9.5 mm) OD Copper	450 (1705.5)	445 (1686.6)	440 (1667.6)	415 (1572.9)	380 (1440.2)	45 (13.7 m)	19.5	6 (1.8 m)	14 (6.4 Kg)

VCL-45ULS SERIES

REPLACEMENT PARTS & KITS

Item	Part Number
Tank	153502
Cover, Switch Assy.	153537
Seal Ring	928025
Impeller	153520
Switch, Pump	950337
Overflow Detection Switch	950333

ENGINEERING DATA

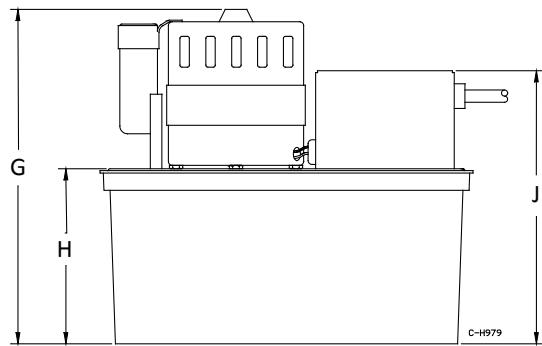
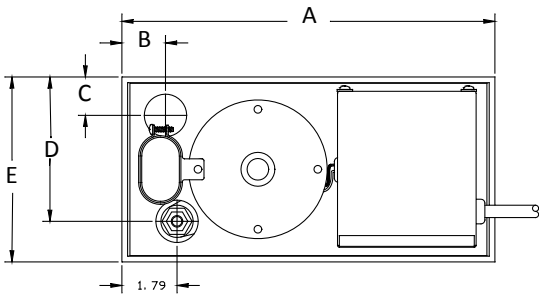

A	B	C	D	E	F	G	H	J
12.11 (307.59)	1.42 (36.07)	1.24 (31.50)	4.68 (118.87)	6 (152.4)	1.79 (45.47)	10.85 (275.59)	5.68 (144.27)	8.86 (225.04)

PERFORMANCE DATA

115 V AND 230 V, 60 HZ

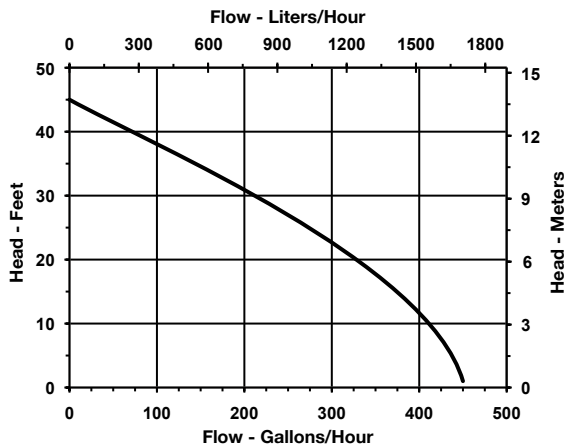

CONSTRUCTION

Pump Housing	ABS
Switch Housing	ABS
Tank	ABS
Tank Cover	Galvanized Steel
Motor Shaft	Stainless Steel
Impeller	Polypropylene
Discharge	3/8" copper tube

1-ABS SERIES

APPLICATIONS

- Utilizing a sealed, submersible pump with sump-type pick-up, the 1-ABS offers low on and off levels and is ideal for in-pan placement for condensate removal. An integrated, unique float switch design assures reliability and security while providing easy access to the float for servicing.

FEATURES

- Permanently lubricated motor bearings require no maintenance during life of pump
- Oil-filled to maximize heat dissipation
- Epoxy-coated cast aluminum pump housing
- Automatic on-off operation
- Easy to remove float housing for servicing
- Includes removable inlet filter screen
- Includes 90° 1/4" MNPT adapter (suitable for 1/2" I.D. vinyl tubing)
- Low on and off level – turns on at 1-3/4" and off at 1-1/4" – will operate in most standard condensate drain pans
- Includes 9 ft power cord with molded plug (115 V versions)
- Item 550522 includes tank
- Suitable for intermittent water temperature up to 120 °F



SERIES SPECIFICATIONS

Item No.	Model	HP	Input Voltage	Hz	Amps	Watts	Discharge Size	Performance GPH (LPH) @ Head			Shut-Off Ft.	PSI	Cord	Weight (lbs)
								1'	3'	5'				
550521	1-ABS	1/150	115	60	1.1	70	1/4" MNPT	205 (777)	180 (682.2)	145 (549.6)	10' (3 m)	4.3	9' (2.7 m)	4.11 (1.86 Kg)
550532	1-ABS	1/150	230	50/60	0.6/0.5	70	1/4" MNPT	205 (777)	180 (682.2)	145 (549.6)	10' (3 m)	4.3	11' (3.4 m)	4.31 (1.95 Kg)
550522	1-ABS with tank	1/150	115	60	1.1	70	1/4" MNPT	205 (777)	180 (682.2)	145 (549.6)	10' (3 m)	4.3	9' (2.7 m)	4.35 (1.97 Kg)

1-ABS SERIES

REPLACEMENT PARTS & KITS

Item	Part Number
Volute	116375
Impeller	116437
Seal Ring	928007
Screen	101376
Tank	150102 (for 550552 only)
Float Replacement	950060
Float Screen	950284

ENGINEERING DATA

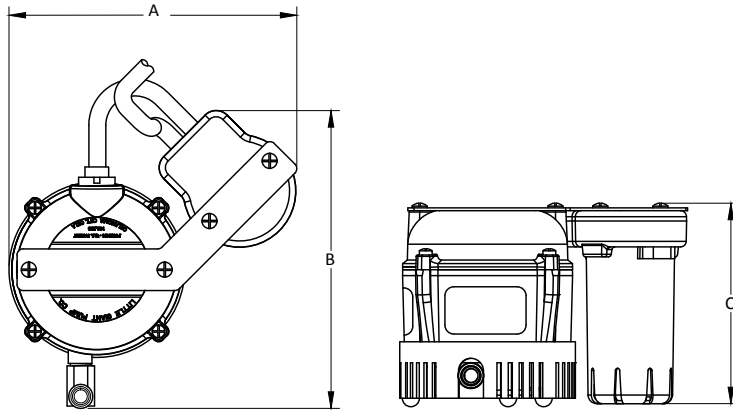

A	B	C
6.09 (154.7)	6.32 (160.5)	4.31 (109.5)

PERFORMANCE DATA

115 V AND 230 V, 60 HZ

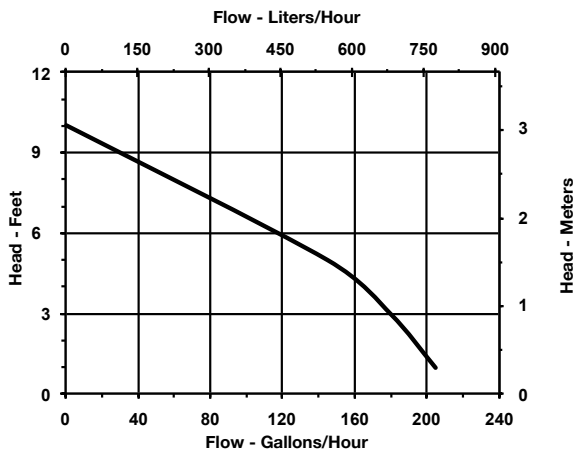

CONSTRUCTION

Motor	1/50 hp
Discharge	1/4" MNPT
Housing	Epoxy-coated cast aluminum
Cover	Epoxy-coated cast aluminum
Volute	Nylon
Impeller	Nylon
Shaft Seal	Nitrile
Screen	Polypropylene
Switch Bracket	Stainless steel
Switch	ABS

2-ABS SERIES

APPLICATIONS

- Utilizing a sealed submersible pump, the 2-ABS is ideal for in-pan placement for condensate removal. An integrated unique float switch design assures reliability and security while providing easy access to the float for servicing.

FEATURES

- Permanently lubricated motor bearings require no maintenance during life of pump
- Oil-filled to maximize heat dissipation
- Epoxy-coated cast aluminum pump housing
- Easy to remove float housing for servicing
- Includes removable inlet filter screen
- ¼" MNPT discharge is suitable for ½" I.D. vinyl tubing
- Automatic operation:
On level: 3" Off Level: 2"
- Suitable for intermittent water temperature up to 120 °F
- Includes 9 ft power cord with molded plug (115 V version)



SERIES SPECIFICATIONS

Item No.	Model	HP	Input Voltage	Hz	Amps	Watts	Discharge Size	Performance GPH (LPH) @ Head				Shut-Off Ft.	PSI	Cord	Weight (lbs)
								1'	3'	5'	10'				
551020	2-ABS	1/40	115	60	1.7	100	1/4" MNPT	300 (1137)	255 (966.5)	205 (777)	70 (265.3)	11.8' (3.6 m)	5.1	9' (2.7 m)	6.8 (3.1 Kg)
551030	2-ABS	1/40	230	50/60	0.9/0.7	100	1/4" MNPT	300 (1137)	255 (966.5)	205 (777)	70 (265.3)	11.8' (3.6 m)	5.1	11' (3.4 m)	7 (3.12 Kg)

2-ABS SERIES

REPLACEMENT PARTS & KITS

Item	Part Number
Volute	102378
Impeller	102470
Seal Ring	102601
Screen	101376
Tank	150102
Float Replacement	950061
Float Screen	950284

ENGINEERING DATA

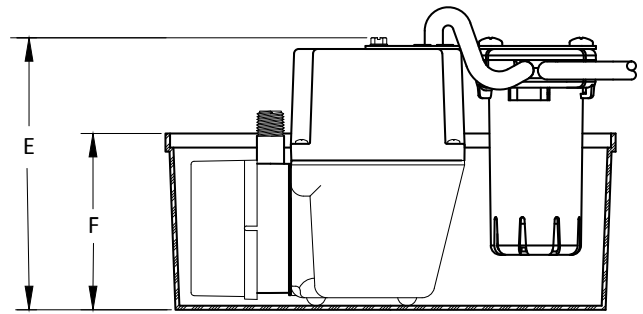
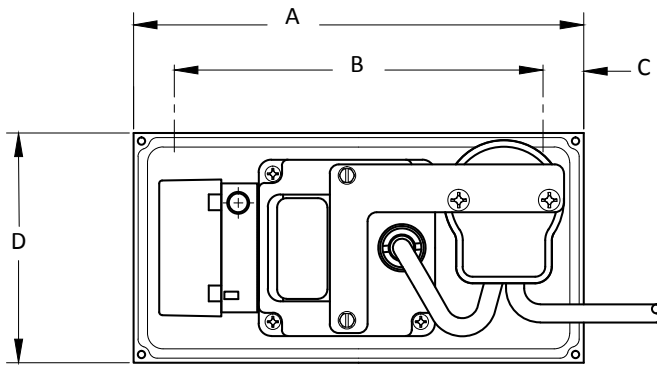

C-M989

A	B	C	D	E	F
8.94 (227.08)	7.32 (185.93)	0.81 (20.57)	4.56 (115.82)	4.9 (124.46)	3.5 (88.9)

PERFORMANCE DATA

115V AND 230 V, 60 HZ

Flow - Liters/Hour

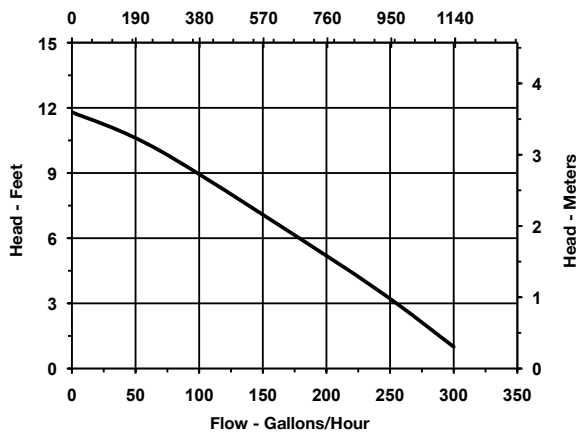

CONSTRUCTION

Motor	1/40 hp
Discharge	1/4" MNPT
Housing	Epoxy-coated cast aluminum
Cover	Epoxy-coated cast aluminum
Volute	Nylon
Impeller	Nylon
Shaft Seal	Nitrile
Screen	Polyethylene
Switch Bracket	Stainless steel

3-ABS SERIES

APPLICATIONS

- Utilizing a sealed, submersible pump with collection tank, the 3-ABS is an ideal choice for a self-contained, high volume, high head condensate removal pump. An integrated, unique float switch design assures reliability and security while providing easy access to the float for servicing.

FEATURES

- Includes 1 gallon ABS tank
- Permanently lubricated motor bearings require no maintenance during life of pump
- Oil-filled to maximize heat dissipation
- Epoxy-coated cast aluminum pump housing
- Galvanized steel tank cover has 1-1/8" inlet opening
- Automatic operation:
On level – 4.5" Off Level – 3.5"
- Easy to remove float housing for servicing
- Includes removable inlet filter screen
- 1/2" MNPT pump discharge with brass check valve and compression fitting for 1/2" OD copper or rigid plastic tubing
- Powerful 1/12 hp pump motor
- Suitable for intermittent water temperature up to 120 °F
- Includes 9 ft power cord with molded plug (115 V version)



SERIES SPECIFICATIONS

Item No.	Model	HP	Input Voltage	Hz	Amps	Watts	Discharge Size	Performance GPH (LPH) @ Head					Shut-Off Ft.	PSI	Cord	Weight (lbs)
								1'	3'	5'	10'	20'				
551320	3-ABS	1/12	115	60	3.5	210	1/2" MNPT	310 (1175)	290 (1099.1)	280 (1061.2)	250 (947.5)	110 (417)	26' (7.9 m)	11.2	9' (2.7 m)	12 (5.44 Kg)
551330	3-ABS	1/12	230	50/60	1.8/1.6	210	1/2" MNPT	310 (1175)	290 (1099.1)	280 (1061.2)	250 (947.5)	110 (417)	26' (7.9 m)	11.2	9' (2.7 m)	12 (5.44 Kg)

3-ABS SERIES

REPLACEMENT PARTS & KITS

Item	Part Number
Tank	153502
Cover	151410
Check Valve	940003
Volute	103376
Impeller	104435
Gasket	103601
Float Replacement	950061
Float Screen	950284
Elbow, Inlet	119007

ENGINEERING DATA

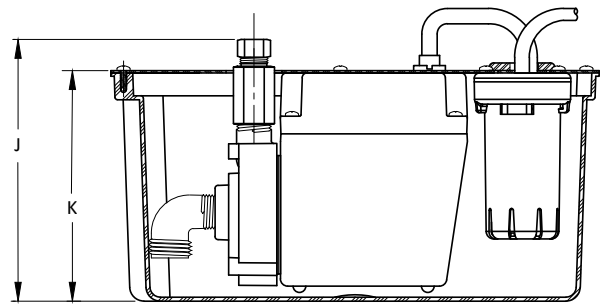
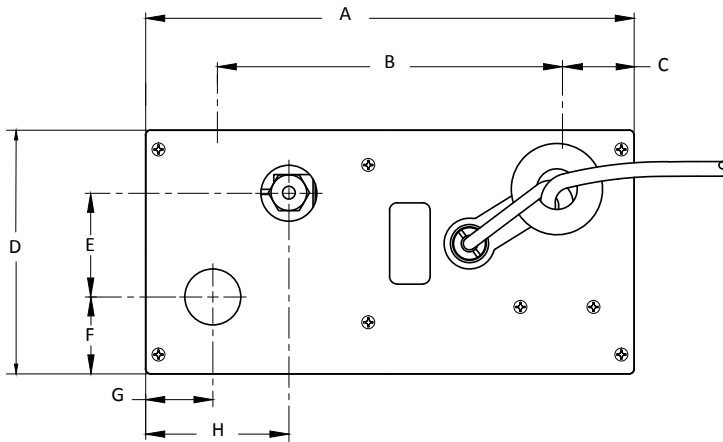

A	B	C	D	E	F	G	H	J	K
12.03 (305.56)	8.5 (215.9)	1.77 (44.96)	6 (152.4)	2.55 (64.77)	1.89 (48.01)	1.66 (42.16)	3.53 (89.66)	6.5 (165.1)	5.68 (144.27)

PERFORMANCE DATA

115 V AND 230 V, 60 HZ

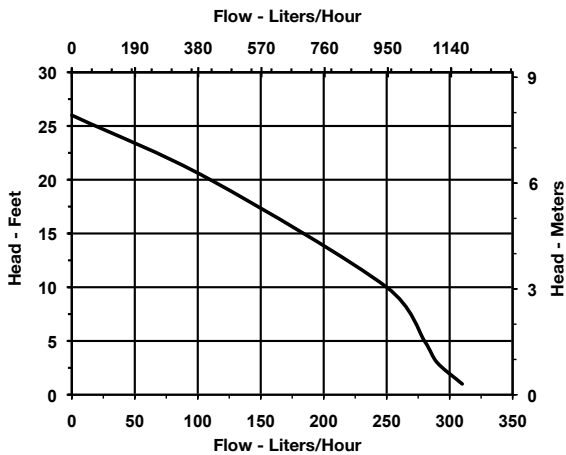

CONSTRUCTION

Motor	1/12 hp
Intake	1-1/4" diameter
Discharge	1/2" MNPT
Pump Housing/Cover	Epoxy-coated cast aluminum
Tank Cover	Galvanized steel
Volute	Nylon
Impeller	Nylon
Shaft Seal	Nitrile
Screen	Polyethylene

EC-1-DV SERIES

APPLICATIONS

- The EC-1-DV model is designed to accommodate multiple electrical requirements within one pump. The DV suffix indicates that the pump is capable of operating from a wide range of supply voltage to maintain consistent pump performance.
- The EC-1-DV Series is a new concept for mini pumps incorporating an improved noise reducing design and reliable solid-state switching technology. Easy to install brackets provide a quick and precise method to accurately position and secure both parts of the pump quickly. The two-piece design allows the reservoir to be placed within the air handler while the pump-controller is located outside the air handler. The two components are connected via a convenient communications wire and suction tubing.
- EC-1-DV is designed for use in removing condensate from wall mount, ductless mini-split air conditioners up to 34,000 Btu. It can also be used to remove condensate from fan coils and suspended ceiling air conditioners. The pump can be installed above the air conditioner in a false ceiling, behind the wall mount air handler, or in plastic conduit or line-set channel. The reservoir, featuring a clear tank, connects to the condensate drain hose and must be positioned flat and horizontal while the pump can be oriented in any position within 3.3 ft.



FEATURES

Pump - Controller

- Normally-closed relay rated at 8 A resistive - 250 V alarm
- 21 dB(A)*
- 1/4" I.D. pump discharge outlet
- Elastomeric mounting grommets on pump housing bracket
- Elastomeric passive vibration isolator used to dampen pump vibration
- Separate wall bracket for pump and reservoir included
- Thermal protection: 176 °F
- 60" power cable
- 3.3' communications cable (pump to reservoir)
- Ambient temperature range: 32 °F - 140 °F
- Maximum water temperature: 140 °F
- 2-year warranty

Reservoir

- Clear reservoir for instant visual inspection of water level, float, and filter
- Hall effect on/off level sensors with high-water sensor feature
- Extra-large filter screen for longer intervals between cleaning
- Multi-step drain hose adapter (1/2", 5/8", and 3/4")
- Simple to open reservoir for easy maintenance

EC-1-DV SERIES

SERIES SPECIFICATIONS

Item No.	Model	Input Voltage	Hz	Amps	Watts	Discharge Size	Performance GPH (LPH) @ Head					Shut-Off Ft.	Suction Lift	PSI	Cord	Weight (lbs)
							0'	1'	5'	10'	20'					
553507	EC-1-DV	110-240	50/60	0.18	18	1/4"	2.7 (10)	2.5 (9.5)	1.8 (6.8)	1.5 (5.7)	1.2 (4.5)	33 (10m)	3' (.91 m)	26	4.9 (1.5 m)	1.7 (0.77 Kg)

ENGINEERING DATA

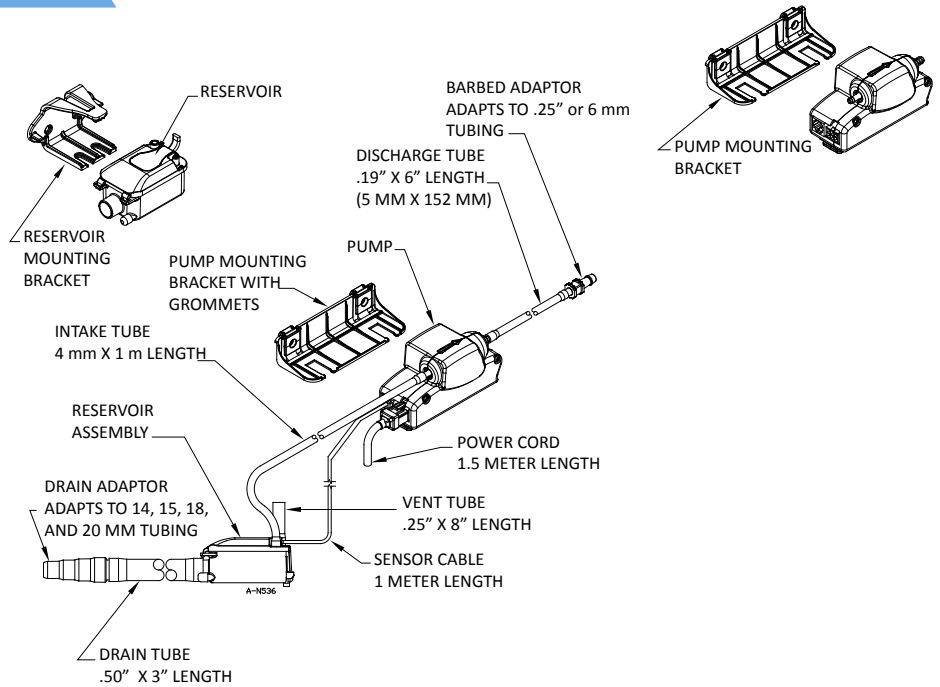
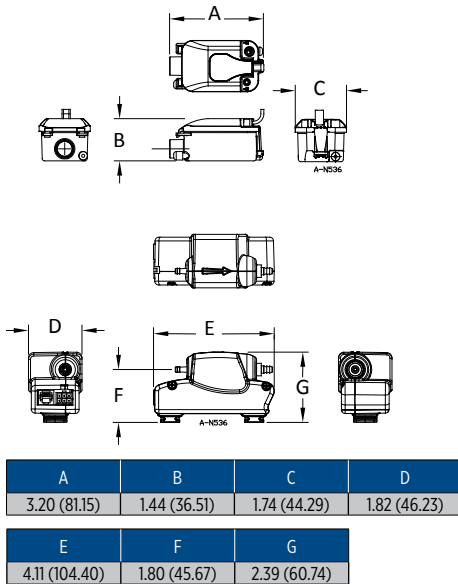

PERFORMANCE DATA

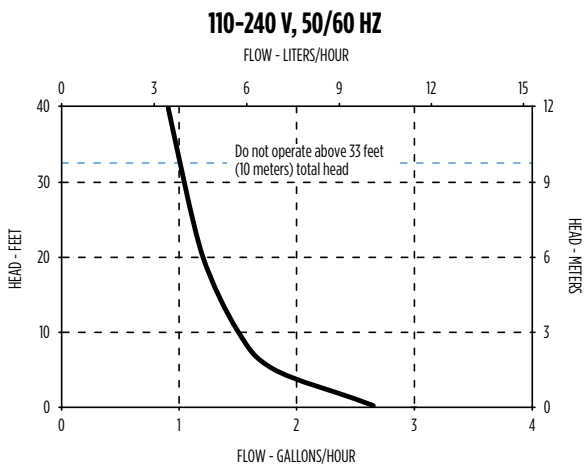

*Tested under conditions assumed consistent with competitors' published sound ratings.

EC-1K-DV SERIES

APPLICATIONS

- The EC-1K-DV model is designed to accommodate multiple electrical requirements within one pump. The DV suffix indicates that the pump is capable of operating from a wide range of supply voltage to maintain consistent pump performance.
- EC-1K-DV Line Set Duct provides space to install the EC-1-DV, line-set pipes, electrical wiring and drain hoses providing a clean, finished look in any décor. The pump is easily accessible for maintenance or cleaning by removing the cover (no tools required). When using the EC-1K-DV Line Set Duct, the EC-1-DV pump is always properly positioned to maximize the quiet operation of the pump and keep the reservoir level for ideal operating performance.

FEATURES

- Includes **EC-1-DV Mini Condensate Pump**
- 21 dB(A)*
- 2.7 gph (10 lph) flow
- 33 ft (10 m) shut off (max. recommended)
- Hall effect switching
- Large inlet filter
- Multi-size hose drain adapter fits all popular drain hose connections
- 2-year warranty

Line Set Kit

- Right- or left-side installation options
- 2.1" x 3.0" (5.3 cm x 7.6 cm) Line Set Duct inside dimension
- 19.7" (50 cm) drain hose tubing
- Detachable power cord 84" (213.4 cm)
- 90° "elbow" for locating pump reservoir
- 31.5" (80 cm) straight line set cover
- Room inside Line Set Duct for 3/8" and 5/8" line set pipe
- Twist motion snap-lock clips and cable ties to secure the line set
- Pump enclosure and pump mounting bracket
- Wall fasteners included (to secure Line Set Duct to wall)
- Air conditioner trim and bracket for "finished" look
- Includes ceiling plate when pump enclosure



EC-1K-DV SERIES

SERIES SPECIFICATIONS

Item No.	Model	Input Voltage	Hz	Amps	Watts	Discharge Size	Performance GPH (LPH) @ Head					Shut-Off Ft.	Suction Lift	PSI	Cord	Weight (lbs)	Dimensions (H x L x W in)
							0'	1'	5'	10'	20'						
553517	EC-1K-DV	110-240	50/60	0.18	18	1/4"	2.7 (10)	2.5 (9.5)	1.8 (6.8)	1.5 (5.7)	1.2 (4.5)	33 (10m)	3' (.91 m)	26	4.9 (1.5 m)	1.7 (0.77 Kg)	4.1" x 1.8" x 2.4" (10.4 cm x 4.6 cm x 6.1 cm)

ENGINEERING DATA

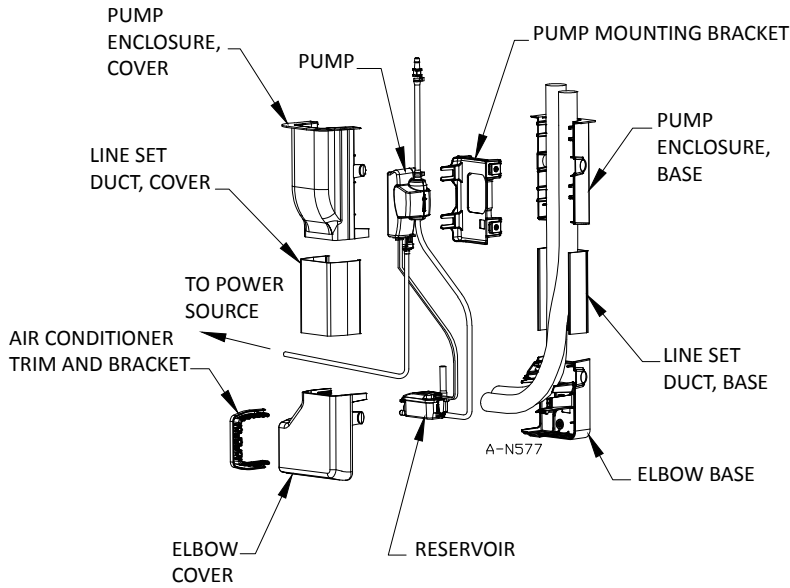

PERFORMANCE DATA

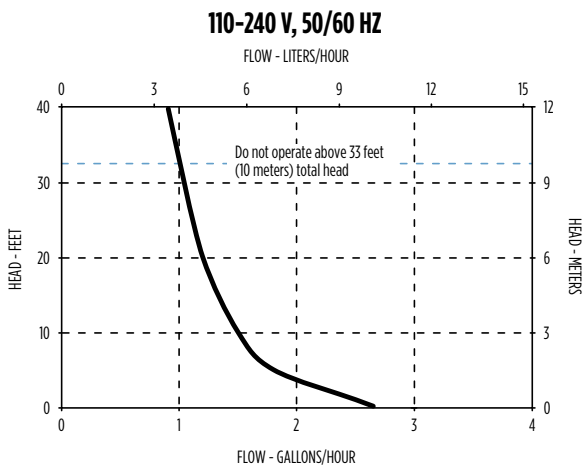

*Tested under conditions assumed consistent with competitors' published sound ratings.

EC-OP-K SERIES

APPLICATIONS

- Removes condensate from wall mounted, ceiling and fan coil air conditioning equipment up to 34,000 BTU

FEATURES

- Pump float retainer for easy serviceability
- Clear reservoir for visual inspection of water level, float and filter
- 8A resistive – 250 V alarm contact
- 5/16" inlet tubing with universal adapter
- 5/32" discharge tubing with 1/4" adapter
- 5/32" discharge tubing
- Ambient temperature range 32 ° - 104 °F
- 176 °F thermal protection
- Alarm ready, suitable for Building Automation System
- Easy to install mounting bracket (kit only)
- Quiet operation
- Stylish pump unit cover – fits any décor (kit only)
- Easy to service without removing from the wall
- Requires no space inside the wall mount air conditioner



SERIES SPECIFICATIONS

Item No.	Model	Input Voltage	Hz	Amps	Watts	Performance GPH (LPH) @ Head						Shut-Off Ft.	PSI	Weight (lbs)
						2'	4'	6'	8'	12'	20'			
553712	EC-OP-K	230	50/60	0.1	20	3.6 (13.6)	3.3 (12.5)	3 (11.4)	2.7 (10.2)	2 (7.6)	1.2 (4.5)	34.77 (10.6 m)	15	3 (1.4 KG)

EC-OP-K SERIES

ENGINEERING DATA

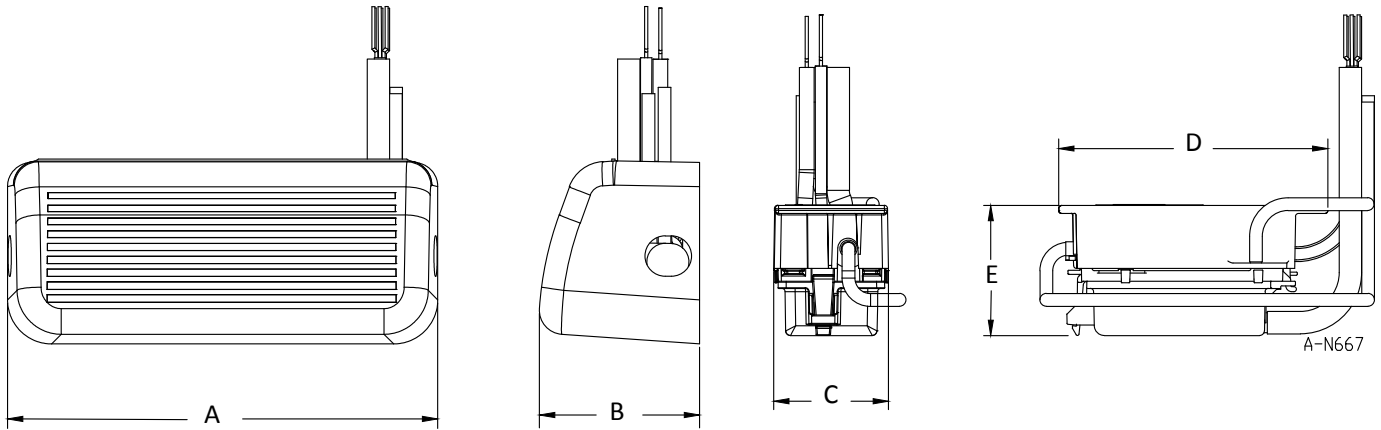

A	B	C	D	E
8.43 (214.12)	3.14 (79.76)	2.25 (57.15)	5.27 (113.86)	2.55 (64.77)

PERFORMANCE DATA

230 V, 60 HZ

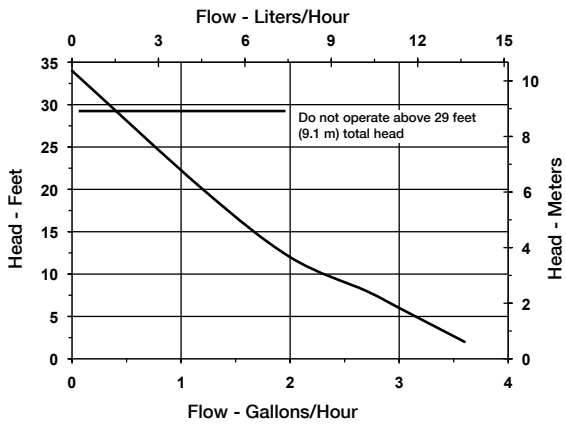

CONSTRUCTION

Material	Flame retardant ABS
Fuse	3A max
Filter Screen	Stainless steel

CP SERIES

APPLICATIONS

- For use in evaporative coolers, sales displays, laboratories, water bath circulation and many other uses. Ideal as a universal OEM replacement pump
- Ideal for residential, commercial, and industrial cooler pump replacement

FEATURES

- High quality concentric fan-cooled double coil motor
- Thermal overload protection
- One-piece corrosion resistant steel shaft
- Universal mounting configurations
- 45° discharge adapter
- Optional 90° elbow with bleed off port available
- Low pump down and recovery level
- Grounded electric plug
- 5 ft electric cord on CP1 and CP2 models
- 6 ft electric cord on CP3 models
- Flame retardant housing
- Snap-off volute plate for easy cleaning



SERIES SPECIFICATIONS

Item No.	Model	HP	Input Voltage	Hz	Amps	Watts	Discharge Size	Performance GPH (LPH) @ Head				Shut-Off Ft.	PSI	Cord	Weight (lbs)
								1'	3'	5'	10'				
540005	CP1-115	1/70	115/127	60	0.8	70	1/2", 5/8", 3/4"	307 (1164)	265 (1004)	213 (807)	-	9.5 (2.9 m)	4.1	5 (1.5 m)	2.5 (1.1 Kg)
540015	CP1-230	1/70	230	50/60	0.4	70	1/2", 5/8", 3/4"	307 (1164)	265 (1004)	213 (807)	-	9.5 (2.9 m)	4.1	5 (1.5 m)	2.5 (1.1 Kg)
541005	CP2-115	1/50	115	60	1.0	80	5/8", 3/4"	502 (1903)	440 (1668)	371 (1406)	89 (337)	11 (3.4 m)	4.8	5 (1.5 m)	3 (1.4 Kg)
541015	CP2-230	1/50	230	50/60	0.5	80	5/8", 3/4"	502 (1903)	440 (1668)	371 (1406)	89 (337)	11 (3.4 m)	4.8	5 (1.5 m)	3 (1.4 Kg)
542005	CP3-115	1/30	115	60	1.1	90	5/8", 3/4"	563 (2134)	512 (1941)	460 (1743)	231 (876)	12 (3.7 m)	5.2	6 (1.8 m)	3.5 (1.6 Kg)
542015	CP3-230	1/30	230	50/60	0.56	90	5/8", 3/4"	563 (2134)	512 (1941)	460 (1743)	231 (876)	12 (3.7 m)	5.2	6 (1.8 m)	3.5 (1.6 Kg)

CP SERIES

ENGINEERING DATA

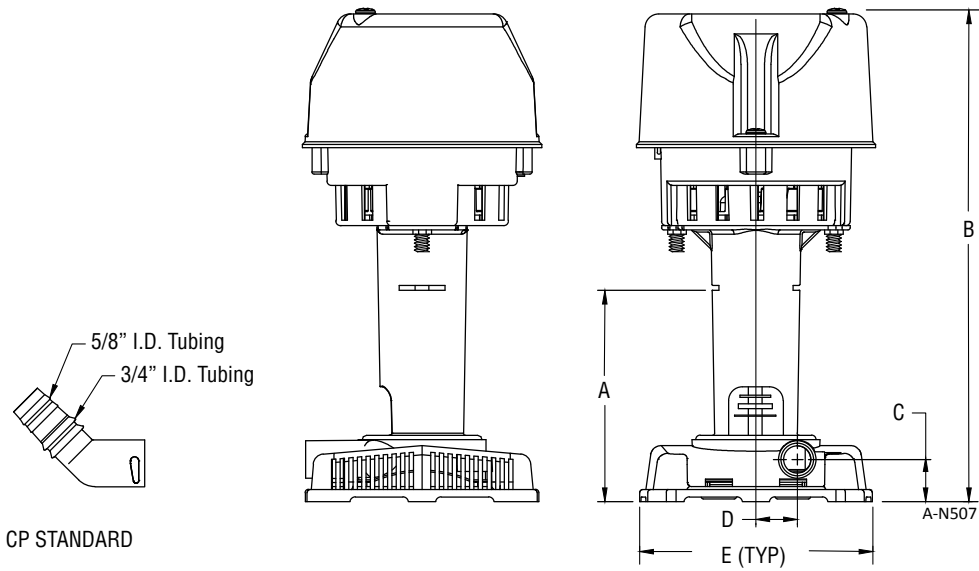

A	B	C	D	E
3.85 (97.79)	8.95 (227.33)	0.8 (20.32)	0.78 (19.81)	4.25 (107.95)

PERFORMANCE DATA

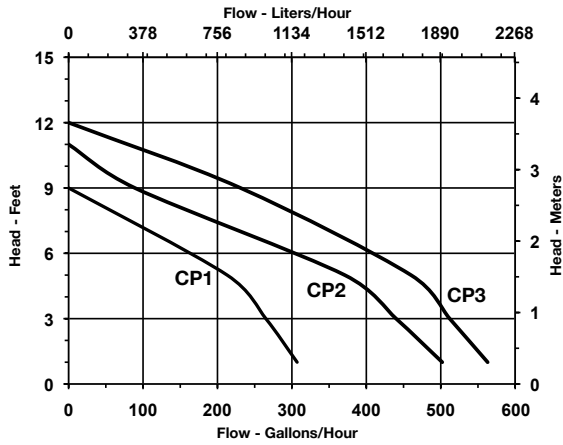

CONSTRUCTION

Motor	Heavy duty fan cooled
Housing	Flame retardant thermal plastic
Motor Cover	Flame retardant thermal plastic
Volute	Flame retardant thermal plastic
Impeller	Polyester
Mounting Bracket	Galvanized steel

RIM-U SERIES

APPLICATIONS

- Commercial ice machine universal replacement water pump

FEATURES

- Dual voltage (115/230 V, 50/60 Hz) 1/25 hp fan cooled motor
- Upper and lower sealed ball bearings
- Thermally protected
- Moisture proof windings
- Corrosion resistant stainless steel motor shaft
- 3 ft 4-wire leads
- Pump easily disassembles for installing and servicing
- Designed to re-use original ice machine OEM pump mounting bracket
- Multiple impellers (included) to match most US-made ice machine OEM water pump specifications
- Multiple discharge adapters (included) to match most US-made ice machine OEM water pumps specifications, including 1/2", 5/8", 3/4", 1", plus a "Y" adapter for 5/8" tubing



SERIES SPECIFICATIONS

Item No.	Model	HP	Input Voltage	Hz	Amps	Watts	Discharge Size	Lead Wires (ft)	Weight (lbs)
545600	RIM-U	1/25	115/230	50/60	1.5/.75	125	1/2", 5/8", 3/4", 1", 5/8" Y O.D.	3 (0.9 m)	4.31 (2.0 Kg)

RIM-U SERIES

REPLACEMENT PARTS & KITS

Item Number	Part Number	Description	Qty.
1	145463	Impeller/adaptor assembly pack (4) Impeller sizes (5) Discharge adapters (6) Volute thumb screws (1) Impeller spring (1) Impeller thumb screw (1) O-ring seal	1
2	145459	Stand	1
3	145461	Slinger plate	1
4	921073	Flat washer	2
5	921072	Locking washer	2
6	920026	Thumb nut (motor)	2
7	145460	Volute	1

ENGINEERING DATA

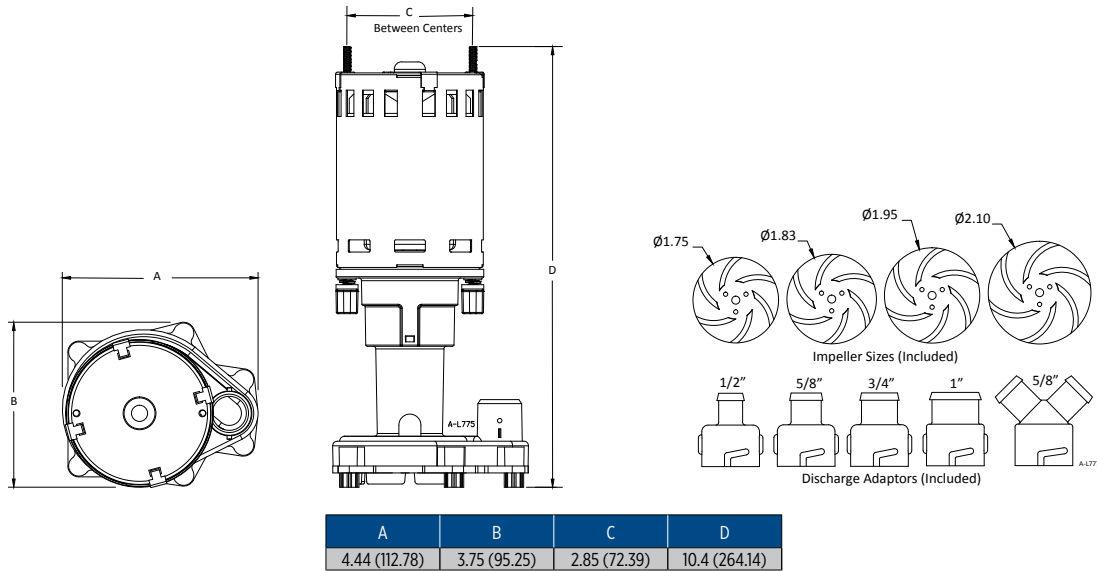

PERFORMANCE DATA

Impeller Diameter	Discharge Adapter (I.D. Tubing Size)	Flow - Gallons/Liters per hour	
		2 Ft/.6m	
		GPH	LPH
1.75\" / 44.5 mm	1/2\" / 12.7 mm	290	1097
	5/8\" / 15.8 mm	435	1646
	3/4\" / 19.1 mm	540	2044
	1\" / 24.5 mm	585	2214
1.83\" / 46.5 mm	1/2\" / 12.7 mm	360	1362
	5/8\" / 15.8 mm	550	2081
	3/4\" / 19.1 mm	700	2649
	1\" / 24.5 mm	810	3066
1.95\" / 49.5 mm	1/2\" / 12.7 mm	385	1457
	5/8\" / 15.8 mm	600	2271
	3/4\" / 19.1 mm	760	2876
	1\" / 24.5 mm	825	3122
2.10\" / 53.3 mm	1/2\" / 12.7 mm	400	1514
	5/8\" / 15.8 mm	600	2271
	3/4\" / 19.1 mm	700	2649
	1\" / 24.5 mm	760	2876

CONSTRUCTION

Pump Housing	NSF-listed ABS
Volute	NSF-listed ABS
Impeller(s)	NSF-listed

GKPK-SC SERIES

APPLICATIONS

- For effective cleaning, deliming and descaling of coils
(Coil cleaning chemicals not included)

FEATURES

- 5-gallon polyethylene tank
- Snap-on acrylic tank cover
- Tank baffle to reduce splash
- Includes 2-MD-SC magnetic drive pump with special volute for vertical installation
(Pump only includes cCSAus mark)
- Stainless pump bracket
- 1/2" O.D. intake and discharge
- 10' x 1/2' vinyl tubing
- Intermittent liquid temperature up to 150 °F
- Tubing clamps and adapters included
- Inlet filter screen
- 14.6' maximum head
- 6' power cord



SERIES SPECIFICATIONS

Item No.	Model	HP	Input Voltage	Hz	Amps	Watts	Discharge Size	Performance GPH (LPH) @ Head				Shut-Off Ft.	PSI	Cord	Weight (lbs)
								1'	3'	6'	9'				
562660	GKPK-SC	1/30	115	60	1.4	109	1/2" O.D.	510 (1933)	465 (1763)	410 (1554)	330 (1251)	14.6 (4.5 m)	6.3	6 (1.8 m)	11 (5 Kg)

GKPK-SC SERIES

REPLACEMENT PARTS & KITS

Item	Part Number
Pump	580523
Tank Cover	162125
Baffle	162116
Tubing 1/2" x 18"	944222
Tubing 1/2" x 10"	944213

ENGINEERING DATA

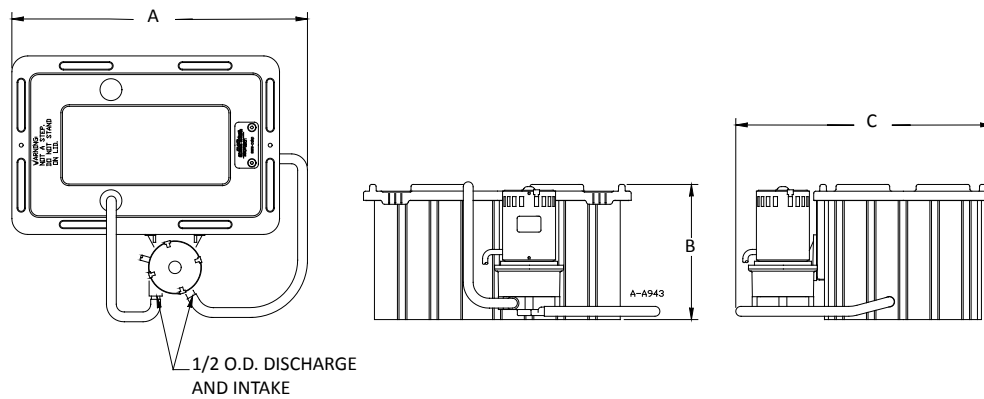

A	B	C
20.00 (50.90)	8.60 (21.84)	16.00 (40.64)

PERFORMANCE DATA

115 V, 60 HZ

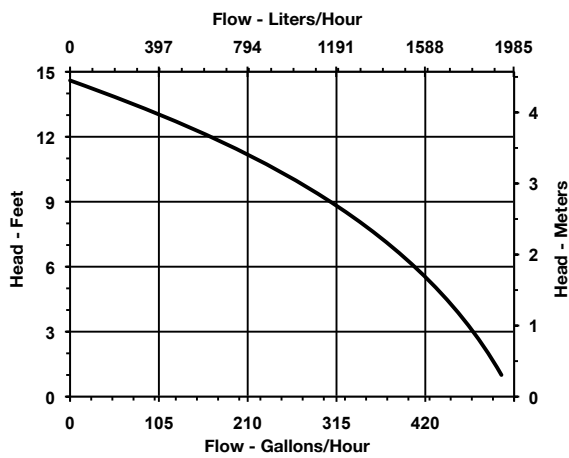

CONSTRUCTION

Tank	Polyethylene
Tank Cover	Acrylic
Pump Head	GF Polypropylene
Pump Shaft/Thrust Washers	Ceramic
Inlet/Outlet Tubing	Vinyl

ACS-2 & 3 IN-PAN CONDENSATE OVERFLOW DETECTION SWITCHES

APPLICATIONS

- The ACS-2 & 3 Condensate Overflow Switches install in air conditioner drain pan to shut off the unit if condensate level approaches overflow.

FEATURES

- Easy to install, inspect and maintain
- Compact design mounts to side of A/C condensate drain pans
- Can be installed to activate audible or visual alarm circuitry
- ABS housing and float
- Complies with applicable building codes
- Switches can be wired to operate as NO or NC
- Operation:
 - ACS-2 — 48 VAC/DC max, 5 amps max
 - ACS-3 — 125-250 VAC max, 11 amps max, up to 1/3 HP
- Lead wires:
 - ACS-2 — 18" and 72" leads
 - ACS-3 — 72" leads



SERIES SPECIFICATIONS

Item No.	Model	HP	Input Voltage	Amps	Lead length	Weight (lbs)
599122	ACS-2	-	48 V AC/DC	5 max.	18" (45.7 cm)	0.21 (0.10 Kg)
599123	ACS-2	-	48 V AC/DC	5 amx.	72" (182.9 cm)	0.29 (0.13 Kg)
599124	ACS-3	1/3 max.	125-250 VAC	11 max.	72" (182.9 cm)	0.29 (0.13 Kg)

ACS-2 & 3 IN-PAN CONDENSATE OVERFLOW DETECTION SWITCHES

ENGINEERING DATA

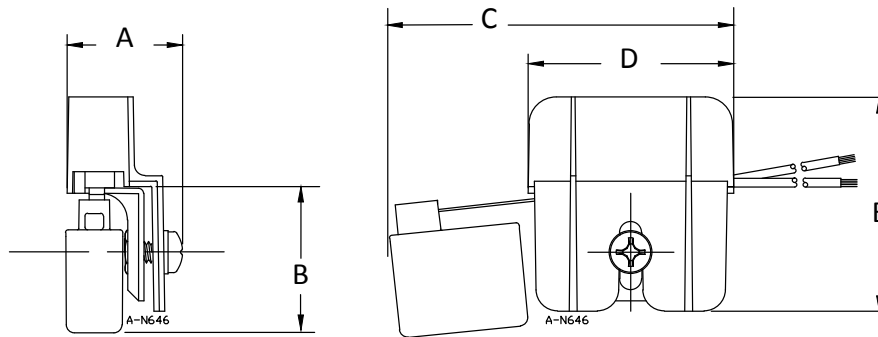

SIDE VIEW

BACK VIEW

A	B	C	D	E
1.34 (34.04)	4.91 (101.6)	2.4 (60.96)	2.5 (63.5)	2.5 (63.5)

TYPICAL INSTALLATION

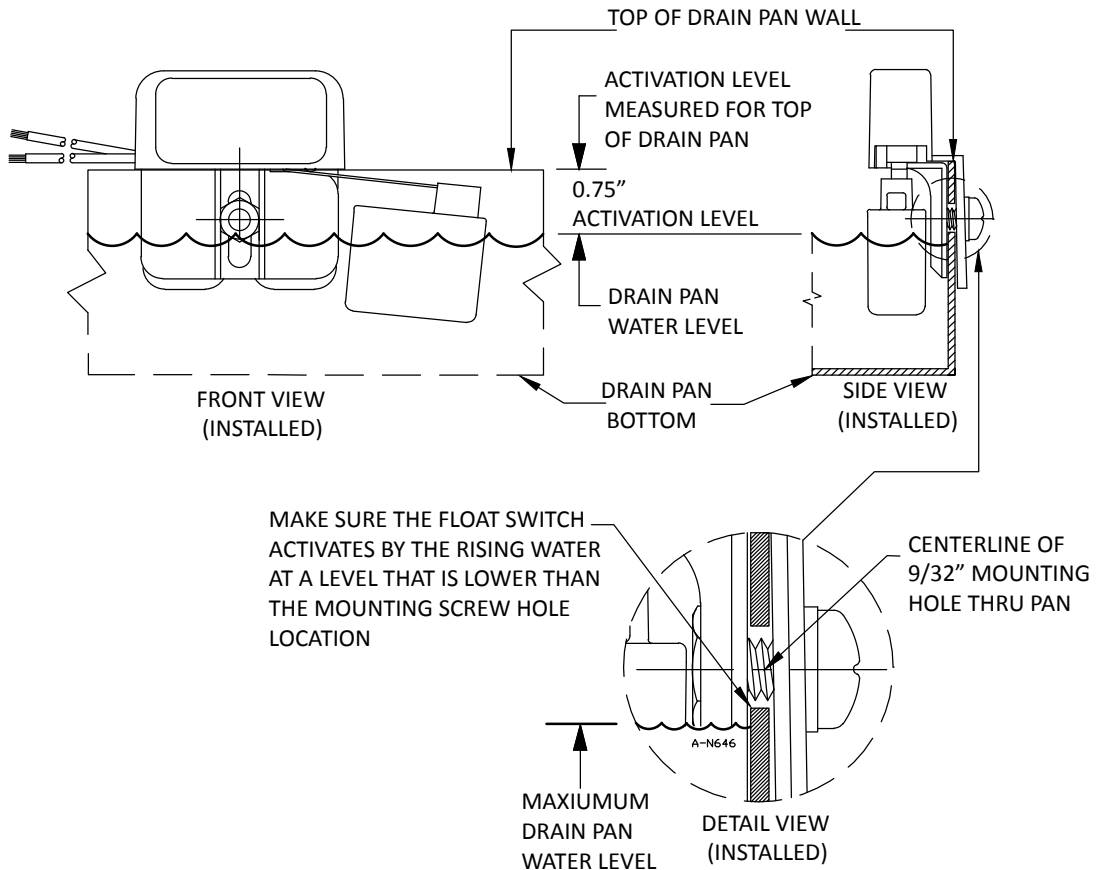

ACS-4 SERIES

APPLICATIONS

- ACS-4 in-line switch is designed to detect condensate drain line clogs or blockages and shut off equipment or alert users to the potential overflow condition. ACS-4 installs on 3/4" PVC condensate drain pipe in either a horizontal or vertical position. Using the included 3/4" PVC drain pan fitting, ACS-4 can also be installed directly at the drain pan secondary outlet to detect pan overflow and shut off equipment or alert users to the potential overflow condition.

FEATURES

- Installs horizontally or vertically for confined spaces
- Reliable mechanical switch and polymer float
- Allows easy access to drain line for cleaning and inspection (by lifting off switch assembly)
- Can be installed in-line on A/C equipment condensate drain pipe, directly at the drain pan outlet or directly at the auxiliary (secondary) drain pan outlet
- Shuts off equipment when clog or blockage backs up condensate water in drain line
- Can simultaneously be connected to a warning light, audible alarm circuit or BMS/BAS system in addition to connection for equipment shut down
- Dual switch contacts allow NO and/or NC operation (additional lead wire required if both circuits used)
- Includes two 18 gauge, 6' (72") leads
- Includes schedule 40 PVC 3/4" 90° (tee) housing, 3/4" MNPT x 3/4" male slip adapter (to fit standard 3/4" equipment pan outlets), 3/4" PVC plug and 1" x 3/4" PVC bushing
- Suitable for 24 VAC Class 2 (thermostat) circuit
- 5 amp switching capacity
- Complies with applicable building codes



SERIES SPECIFICATIONS

Item No.	Model	Input Voltage	Amps
599125	ACS-4	24 VAC	5 max.

ACS-4 SERIES

ENGINEERING DATA

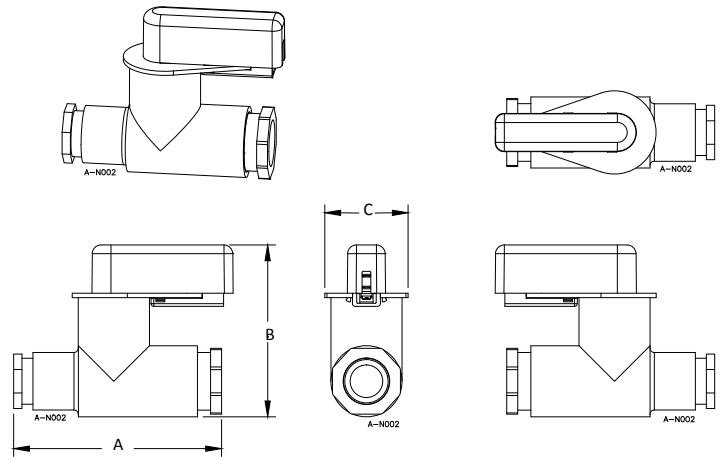
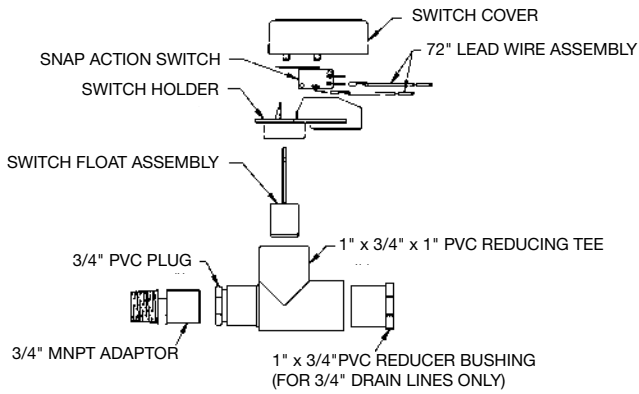

A	B	C
4.7 (119.38)	3.9 (99.06)	1.9 (48.26)

TYPICAL INSTALLATION

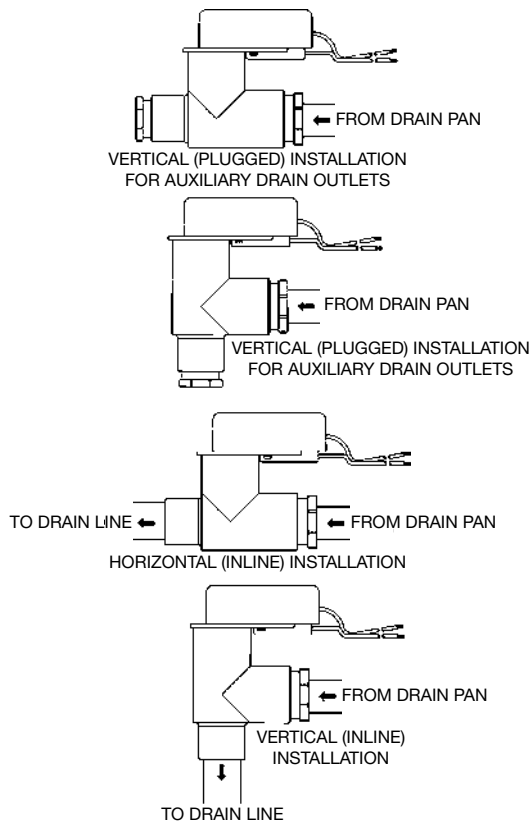

ACS-5 SERIES

APPLICATIONS

- Designed for use as a secondary condensate drain pan overflow detection unit, it will shut off equipment or alert users to potential overflow condition. Easily installs directly to drain pan outlet using included 3/4" PVC drain pan fitting.

FEATURES

- Installs in confined spaces
- Reliable mechanical switch and solid, polymer float
- Can be installed on A/C equipment overflow or secondary drain pan outlet
- Shuts off equipment when clog or blockage backs up condensate water in drain line
- Can simultaneously be connected to a warning light or audible alarm circuit or BMS/BAS system to send a signal in addition to shut off equipment
- Dual contacts allow NO and/or NC operation (additional lead wire required if both circuits used)
- Includes two 18 gauge, 6' leads
- Includes schedule 40 PVC 3/4" 90° housing and 3/4" MNPT x 3/4" male slip adapter to fit standard 3/4" equipment/pan outlets
- Suitable for 24 VAC Class 2 (thermostat) circuit
- 5 amp switching capacity
- Complies with applicable building codes



SERIES SPECIFICATIONS

Item No.	Model	Input Voltage	Amps
14940157	ACS-5	24 VAC	5 max.

ACS-5 SERIES

ENGINEERING DATA

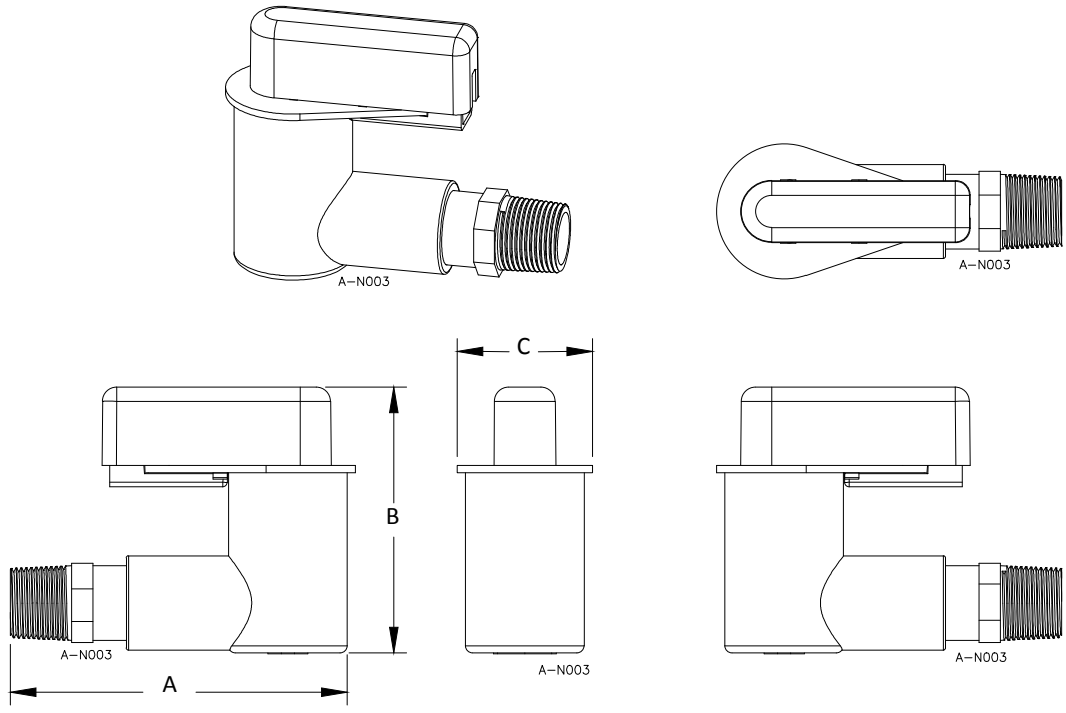

A	B	C
4.7 (119.38)	3.7 (93.98)	1.9 (48.26)

ACCESSORIES

T-20/25

TUBING



Item No.	Model
599033	T-20/25

- One carton of 25 pieces of 20' (6.01 m) length 3/8" (9.5 mm) ID VC tubing

T-3/8

TUBING



Item No.	Model
599107	T-3/8

- 100' (640.1 m) of 3/8" (9.5 mm) ID x 1/2" (12.37 mm) OD clear tubing

PC-10-PRK

PUMP REPAIR KIT



Item No.	Model
599325	PC-10

- Replacement roller and tube kit for TP Series and PC-10

T-RPC-10

TUBE



Item No.	Model
599270	T-RPC-10

- Replacement tube assembly for TPS, TPT, and TPR pumps

ERC

EXTENSION CABLE



Item No.	Model
599170	ERC

- 3.3' (1 m) extension cable for TPT temperature sensor and TPR reservoir assembly

RESERVOIR ASSEMBLY



Item No.	Model
153781	Reservoir Assembly

- Replacement reservoir assembly for TPR pumps

CV-2

CHECK VALVE



Item No.	Model
599061	CV-2

- For ABS Series pumps
- 1/4" FNPT (6.35 mm) to 1/4" (6.35 mm) OD tubing

CV-4

CHECK VALVE



Item No.	Model
599062	CV-4

- For ABS Series pumps
- 1/2" FNPT (12.7 mm) to 1/2" (12.7 mm) OD tubing rigid plastic or copper tubing

CV-35

CHECK VALVE



Item No.	Model
599064	CV-35

- For VCL-45ULS
- 3/8" (9.5 mm) rigid plastic or copper tubing on both ends

CV-10

CHECK VALVE



Item No.	Model
599065	CV-10

- For VCC Series, VCMA Series and VCL-14/24 pumps
- 1/4" FNPT (6.35 mm) to 3/8" (9.5 mm) ID vinyl tubing

CV-X38

CHECK VALVE



Item No.	Model
599058	CV-X38

- For Condensate Pump Series VCMX
- 3/8" (9.5 mm) OD rigid plastic or copper tubing

CV-14/24

CHECK VALVE



Item No.	Model
599069	CV-14/24

- For VCC Series, VCMA Series and VCL-14/24 pumps
- 1/4" MNPT (6.35 mm) to 3/8" (9.5 mm) OD rigid plastic or copper tubing

ACCESSORIES

CV-15/20

CHECK VALVE



Item No.	Model
599033	T-20/25

- Brass check valve for VCMA-15/20
- 1/4" MNPT (6.35 mm) to 3/8" (9.5 mm) OD rigid plastic or copper tubing

ACS-X10

OVERFLOW DETECTION SWITCH



Item No.	Model
599136	ACS-X10

- For use with VCMX

ACS-X72

OVERFLOW DETECTION SWITCH



Item No.	Model
599137	ACS-X72

- For use with VCMX

VCMX-CK

ANTI-SWEAT SLEEVE



Item No.	Model
599138	VCMX-CK

- For use with VCMX

ELBOW



Item No.	Model
140341	Elbow

- For use with CP1 Series
- 90° Elbow with bleed off
- Design for 1/2", 5/8", 3/4" I.D. tubing

ELBOW



Item No.	Model
140346	Elbow

- For use with CP2 and CP3 Series
- 90° elbow with bleed off
- Design for 5/8" and 3/4" I.D. tubing

ADDITIONAL CHECK VALVES

CHECK VALVE



Item No.
154708

- For VCMA, VCM and VCC Series pumps
- 3/8" NPT x 1/4" OD

CHECK VALVE



Item No.
154725

- For use with VCMX
- 1/4" OD

